



PARAGON®

A world of heat you can rely on

**Instruction for user,
Installation & Servicing**



PARAGON

P11

Keep this booklet for service log and future reference

IMPORTANT



This appliance is guaranteed for 24 months subject to conditions. The 3-year extended parts warranty will only be valid if the annual service recommended in this manual has been completed and the appliance has been registered online.

Contents

Benchmark Scheme	2
Introduction	3
Consumer Protection Information.....	3
To light the appliance using the remote handset:.....	5
Cleaning the P11 Appliance	6
Fuel Bed Layout	7
Laying the base matrix and Vermiculite	7
Technical Specification	21
Siting the Appliance	22
Commissioning the Appliance	37
Annual Service Requirement.	40
Fault Finding Charts.....	42
Maintenance	46
Your Fire Years Parts Extended Warranty	50
Four Year Service Log Details.....	51
GAS FIRE COMMISSIONING CHECKLIST.....	52
Register Your 12 Month Warranty with Us Today	53

Benchmark Scheme



Charlton and Jenrick Ltd is a licensed member of the Benchmark Scheme which aims to improve the standards of installation and commissioning of domestic heating and hot water systems in the UK and to encourage regular servicing to optimize safety, efficiency and performance. Benchmark is managed and promoted by the Heating and Hot water Industry Council. For more information and the full code of practice please visit www.centralheating.co.uk

Please ensure that the installer has fully completed the Benchmark Checklist on the inside back pages of the installation instructions supplied with the product and that you have signed it to say that you have received a full and clear explanation of its operation. The installer is legally required to complete a commissioning checklist as a means of complying with the appropriate Building Regulations (England and Wales).

All installations must be notified to Local Area Building Control either directly or through a Competent Persons Scheme. A Building Regulations Compliance Certificate will then be issued to the customer who should, on receipt, write the Notification Number on the Benchmark Checklist.

This product should be serviced regularly to optimize its safety, efficiency and performance. The service engineer should complete the relevant Service Record on the Benchmark Checklist after each service.

The Benchmark Checklist will be required in the event of any warranty.

It is a requirement that the gas fire is installed and commissioned to the manufacturer's instructions and the data fields on the commissioning checklist completed in full.

To instigate the guarantee, the gas fire needs to be registered with the manufacturer within one month of the installation.

To maintain the guarantee, it is essential that the gas fire is serviced annually by a Gas Safe registered engineer. The service details should be recorded on the Benchmark Service Interval Record and left with the householder.

Introduction

The P11 has been designed and tested to the requirements of EN 613 and is suitable for use in Great Britain.

P11 incorporates a single gas valve which selects ignition pilot, with variable setting between low and high setting and is operated via remote control hand device or optional smart app device. This system is powered by mains electricity via pre-wired transformer plus supply cord. Alternative power supply is available for users during mains interruptions.

The P11 incorporates a safety device in form of an Oxygen Depletion System, which constantly monitors the oxygen in the room and will cause the fire to switch off if the oxygen level reduces, for instance due to insufficient ventilation or a blocked flue.

Consumer Protection Information

As manufacturers and suppliers of heating products, we take every care to ensure that the design and construction must meet the general safety requirements when properly used and installed. To this end, our products are thoroughly tested and examined before dispatch.

Any alteration that is not approved by the manufacturer could invalidate the approval of the appliances, operation of the warranty and could affect your statutory rights.

This appliance could contain some materials that could be interpreted as being injurious to health. It is the users / installers responsibility to wear protective clothing when handling the following materials. Artificial fuel, mineral wool, insulation material, refractory/ceramic fibres and glass yarn. May be harmful if inhaled, may be irritating to skin, eye, nose and throat.

When disposing refractory / ceramic materials to keep dust to a minimum these materials should be securely wrapped in polythene and clearly labelled "RCF waste". These materials are not classified as hazardous waste and should be disposed of at a site licensed for disposal of industrial waste.

Important Information

The appliance is for use on Natural Gas (G20 @ 20mbar) or L.P.G. (G31 @ 37mbar).

The Chimney or flue (unless new or previously used with a gas appliance) shall be swept before installation if been used for solid fuel.

In Great Britain, the appliance must be installed by a competent person whose name appears on the gas safe register. All Gas Safe engineers should possess an ID carrying the logo below.



The glass front of this appliance acts as a dress guard, conforming to BS 1945 (1997) however a fireguard to BS6539 (1997) must be used to protect young children, the elderly or infirm.

The Appliance must not be used with the glass safety screen removed or if it is damaged or cracked.

During initial "burn off", an odour may be evident during the first few hours of use. This is due to the surface coating on the metal work "burning off". The odour produced is harmless and will disappear after a short period of time.

During the normal operation of the fire some black staining may appear on some parts of the fuel bed. This is quite normal. However, if excessive black staining occurs it may be due to the fuel bed shapes laid incorrectly. This should be checked prior to contacting a service engineer.

Care must be taken to prevent any damage being caused to surrounding soft furnishing or decoration. Many embossed vinyl coverings may become discoloured if placed too close to the appliance. It is suggested that a sample of the proposed wall covering should be placed above the appliance at its hottest point first. The appliance should then be run on high rate over a couple of days





It is advised that this appliance is serviced annually as recommended by Gas Safe. This is more likely to provide trouble-free operation and is a requirement of the extended warranty.

In GB (Great Britain) the fire does not normally require purpose-built ventilation, but if for any special reason purpose-built ventilation is provided it should be checked periodically to ensure freedom from obstructions.

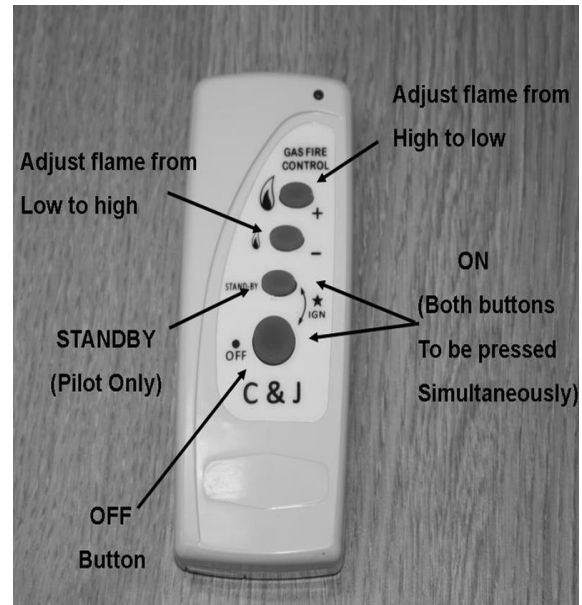
To light the appliance using the remote handset:

- A. Point the remote control handset in the direction of the appliance and simultaneously press the buttons marked 'off' and 'standby'. Continue to hold in these two buttons until a 'bleep' is heard (approximately 2-3 sec.) and then release these buttons. The appliance will automatically go through the ignition sequence and the pilot should ignite. Once the pilot is alight the appliance will automatically go to the high setting (approximately 20-25sec). If the ignitor stops sparking and the pilot fails to light, repeat this procedure.



- B. The appliance can be adjusted up or down by pressing the appropriate button  (low setting) or  (high setting). There are 5 heat settings and the fire will give a double bleep when the maximum or minimum heat setting is reached. To switch off the appliance press the OFF  button or if the appliance is to be switch off for a short period it is recommended that the 'standby' button be used.
- C. The appliance can be switched off without using the handset by unplugging the transformer. When the transformer is removed there will be a delay (up to 3minutes) after which double beeps may be heard and shortly after the appliance will extinguish. Ensure that the transformer is reconnected once the fire has been extinguished. The appliance cannot be operated without the use of the handset. If the fire fails to light or extinguishes for any reason, it will be necessary to re-set the fire. This can be done by pressing the off  button then following the normal lighting procedure.

Note: if repeated delayed ignition is experienced during start-up it is recommended that the appliance is checked by a gas safe engineer

NOTE: If the fire is extinguished for any reason wait 3 minutes before relighting.

P11 USERS INSTRUCTIONS

Low Battery Indication (Handset)

If while pressing any of the buttons on the remote handset the low battery indicator lamp either stops flashing or appreciably slows then the battery should be changed.

To Replace Batteries in Handset (AAA 1.5 v lr3 x2)

Remove the cover from the rear of the handset and fit replacement batteries, taking note of the orientation.

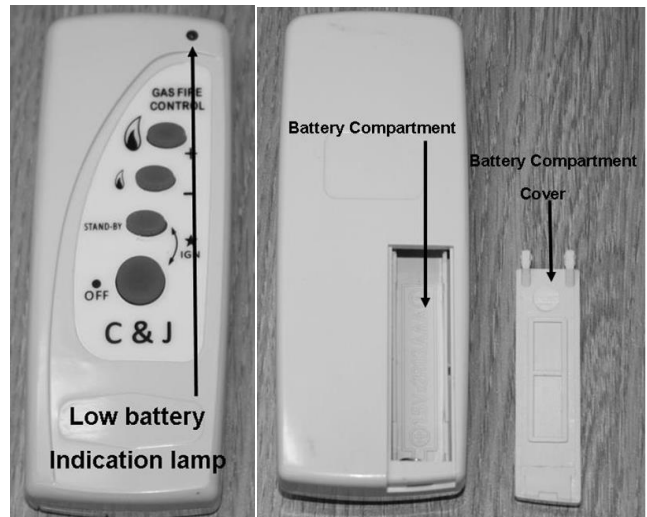

Cleaning the P11 Appliance

Ensure the appliance is cold before proceeding.

The outer metal work frame should be cleaned using a damp cloth.

To clean the glass panel, Remove the Fixing Cover by lifting it up and forwards to allow access to the Top Glass Clamp.

Remove the two M4 nuts fixing the Top Glass Clamp to the glass panel. With the nuts removed, pull the glass clamp clear of the two studs. Finally lift the glass panel out of the bottom glass fixing. Using a damp cloth and warm soapy water will remove most stains. For more substantial marking we recommend the use of ceramic hob cleaner. These are available from all leading supermarkets. The brands of hob cleaner we have tested and found suitable are "Hob brite" & "Bar Keepers Friend". Ensure the glass is dry and re-assemble.

Note- Never operate the appliance when the glass panel is removed or broken. The glass may discolour quickly when first installed, and it should be cleaned. This is due to the burning of the refractory fuel bed shapes.



Cleaning the fuel bed shapes. (Please refer to customer protection information on page 3 of this booklet before cleaning or replacing any refractory materials).

The fuel bed components are delicate, and they should be handled with great care. They can be brushed very gently with a soft brush to remove dust or any deposits. A vacuum cleaner may only be used after the loose components and molded shapes have been removed from the P11 fire box.

It is important that all fuel bed shapes are positioned as shown in these instructions.

Fuel Bed Layout

Laying the base matrix and Vermiculite

First fit the Front Cover making sure it is as close the bottom glass channel as possible and not resting over the Burner, place as shown below.

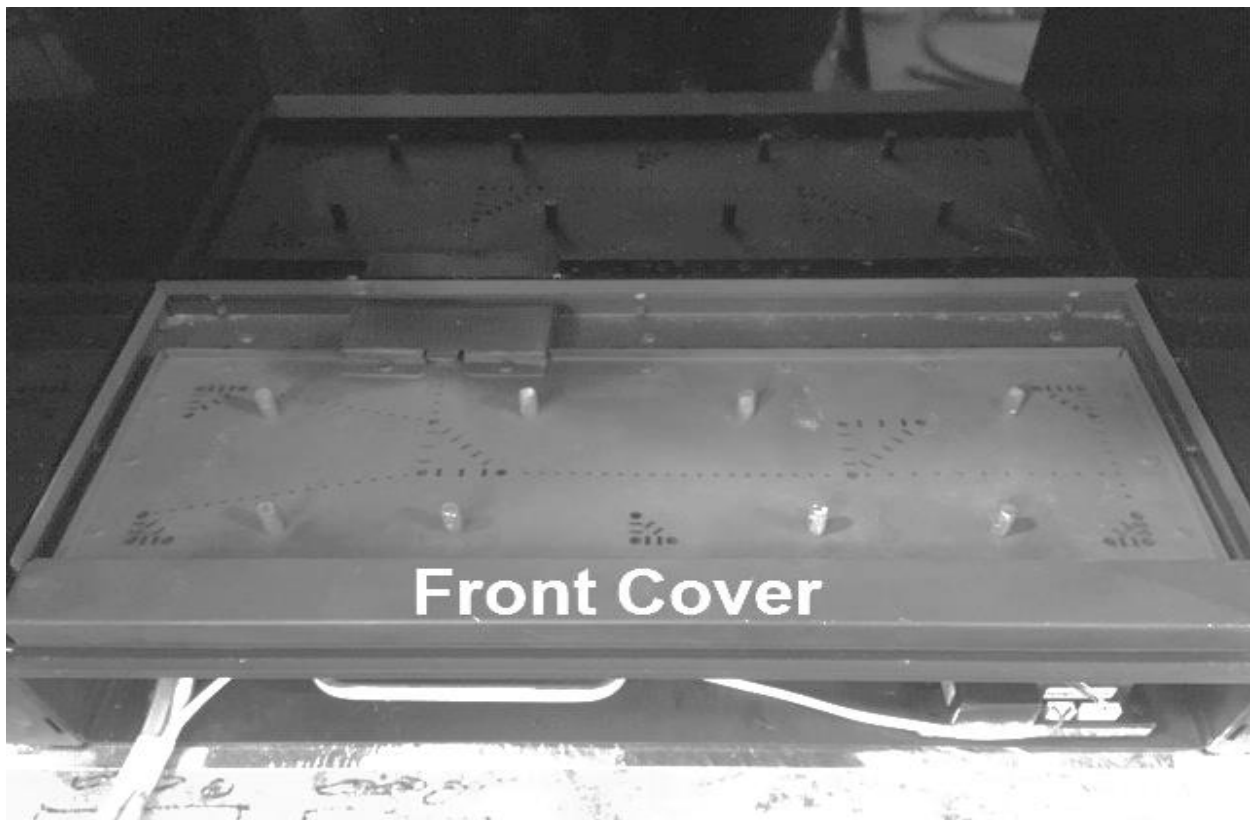

P11 USERS INSTRUCTIONS

Place Shape No.1 onto the pins so it sits flat on the Burner.



Spread a thin layer of the Vermiculite over the Burner base as shown.

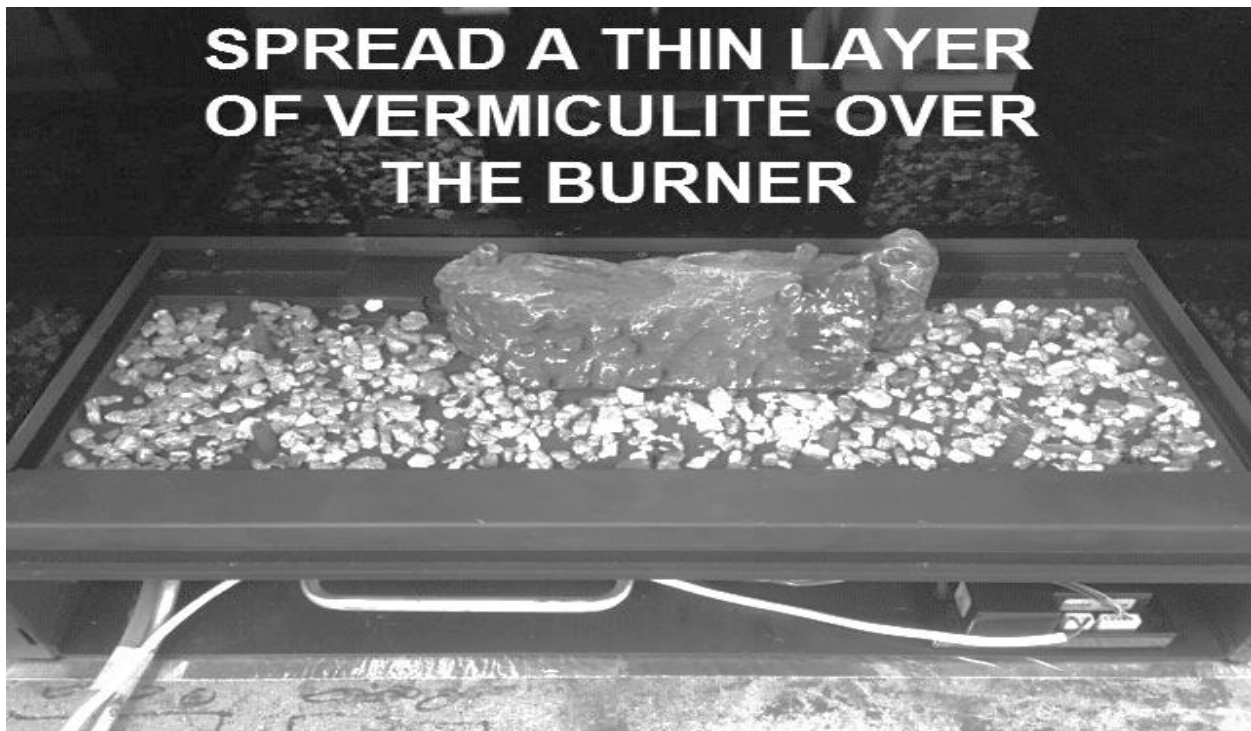

P11 USERS INSTRUCTIONS

When spreading the Vermiculite over the Burner make sure not to block the Pilot area & first line of cross lighting ports , as this may cause ignition problems.

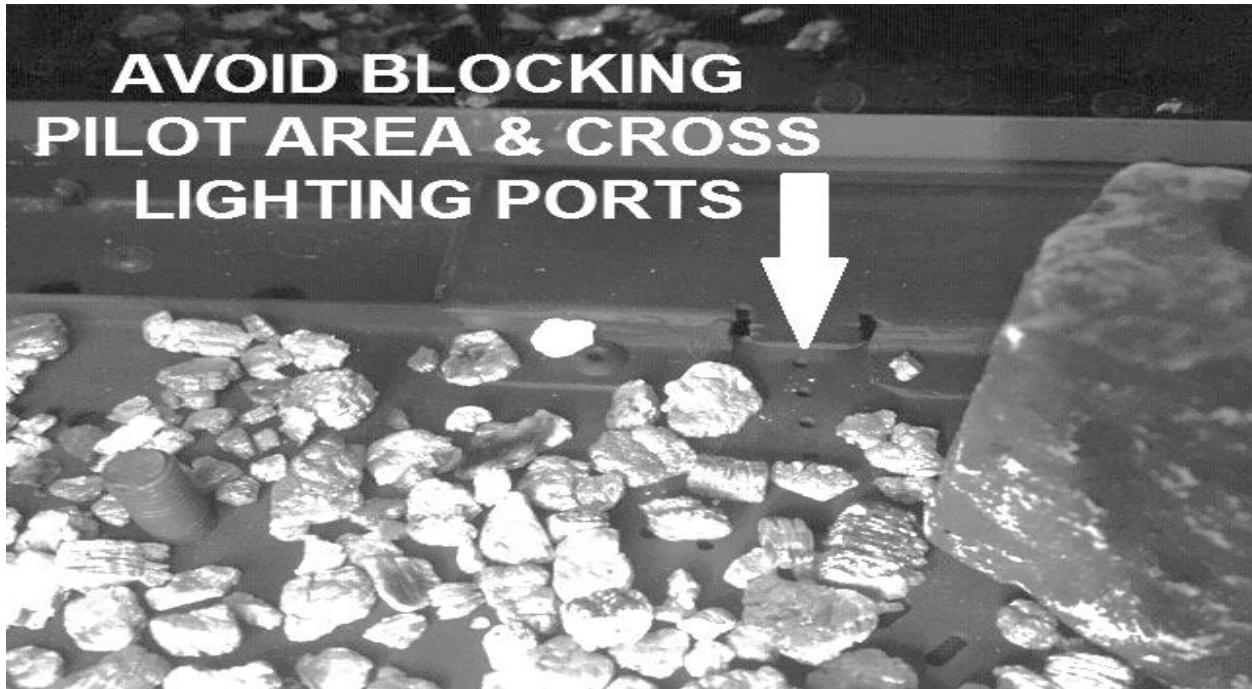

Place Shapes No.2 & No.3 on the pins, making sure they sit flat on the burner, as shown below.

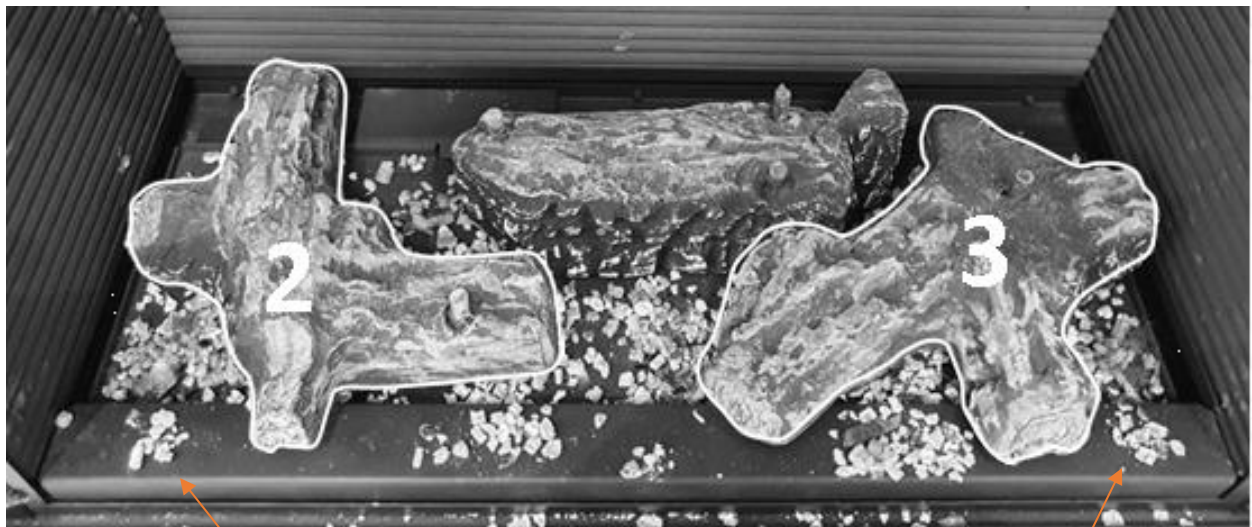

Place some of the vermiculite here along the front edge cover between the logs

P11 USERS INSTRUCTIONS

Take out some of the Embaglow from the packet provided and tease it apart into three pieces, two small pieces and one longer piece, as shown below.



Place the longer piece of Embaglow against shape No.1, then place the two smaller pieces either side of shapes No.2 & No.3, as shown below.



P11 USERS INSTRUCTIONS

Place shape No.4 onto the pin on the lower shape, place shape No.5 as shown, then place No.6 on the pin on top of the lower shape, as shown below.



Place shape No.7, No.8 & No.9 on the lower shape pins as shown below.



P11 USERS INSTRUCTIONS

Place shapes No.10, No.11 & No.12 on the Front Cover & lower shapes as shown below.



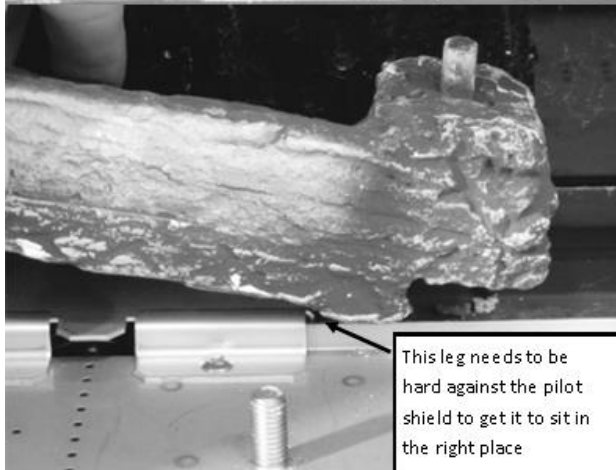
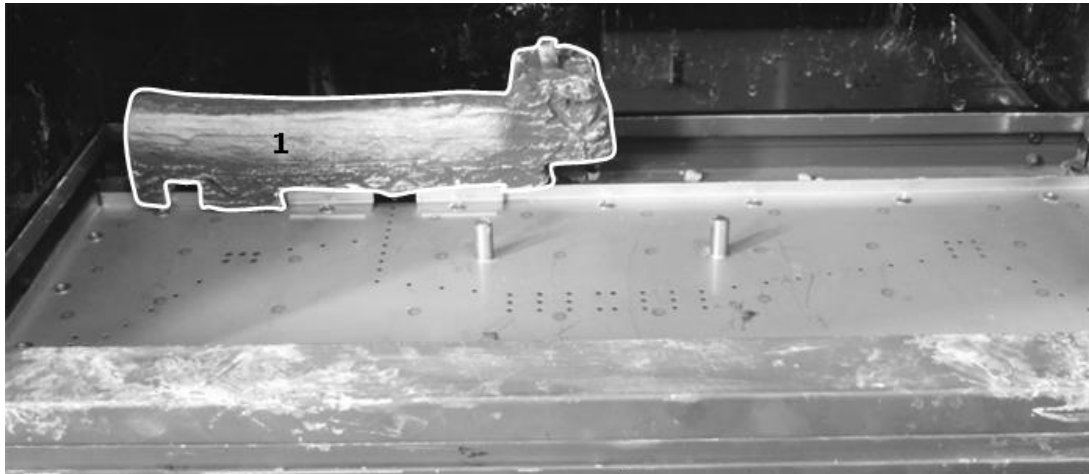
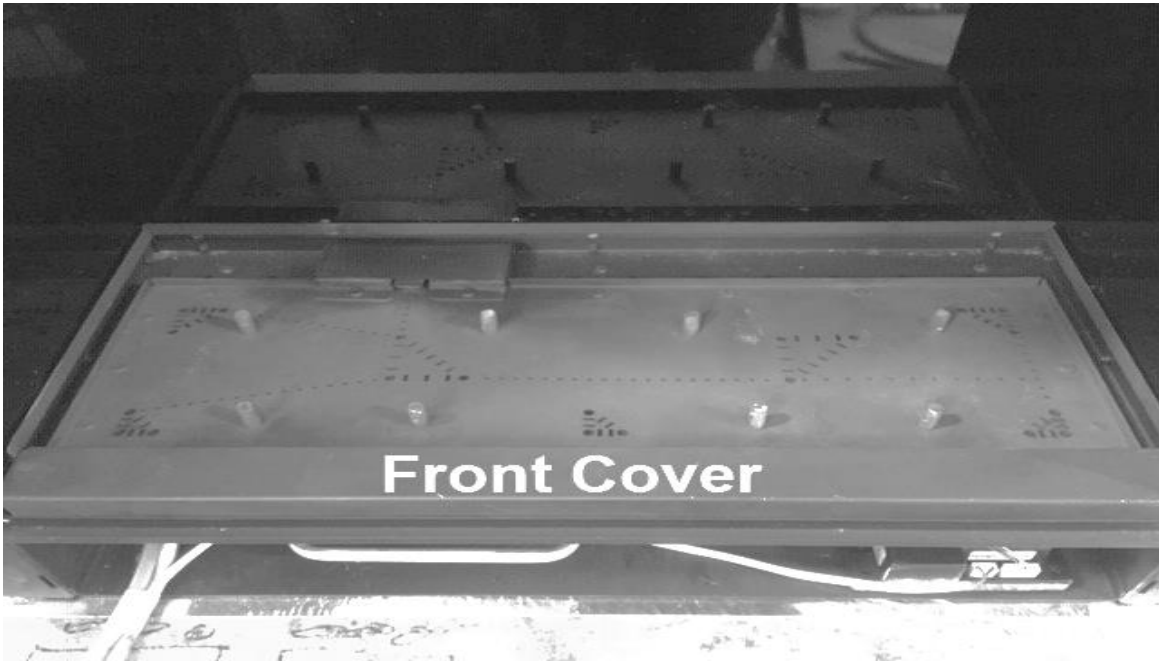

P11 USERS INSTRUCTIONS

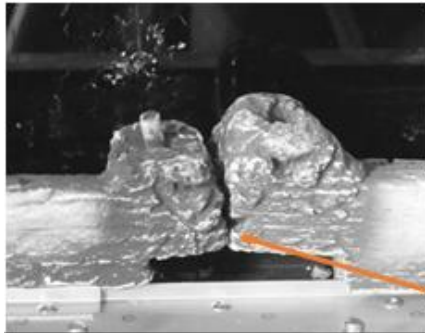

These logs need to be hard against each other and both logs should be sat level

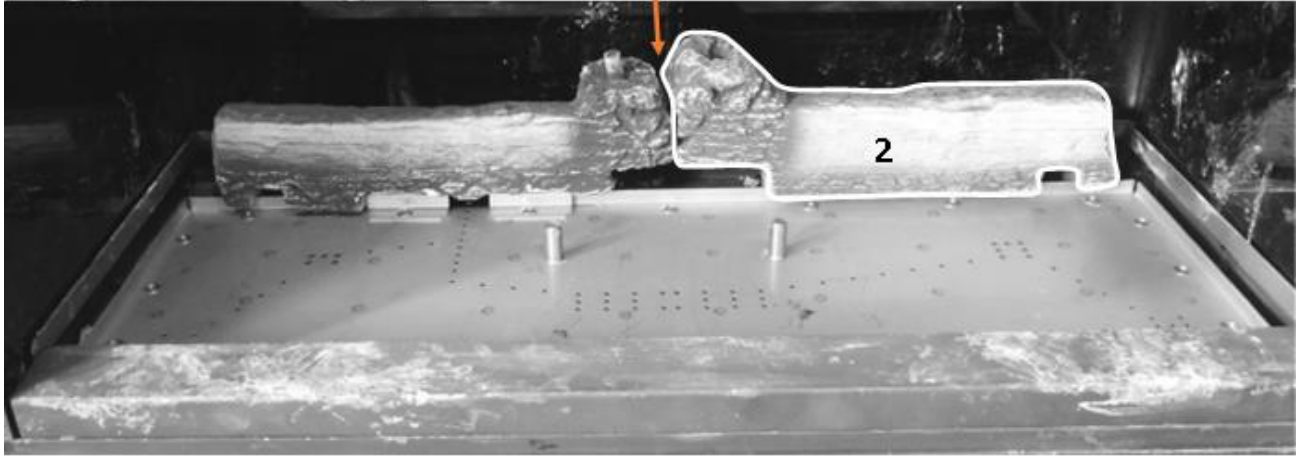

These arrows point to the front face (the face that is facing you when looking at the fuel bed)



P11 USERS INSTRUCTIONS

Using all the vermiculite that comes with the log set place a thin layer across the burner

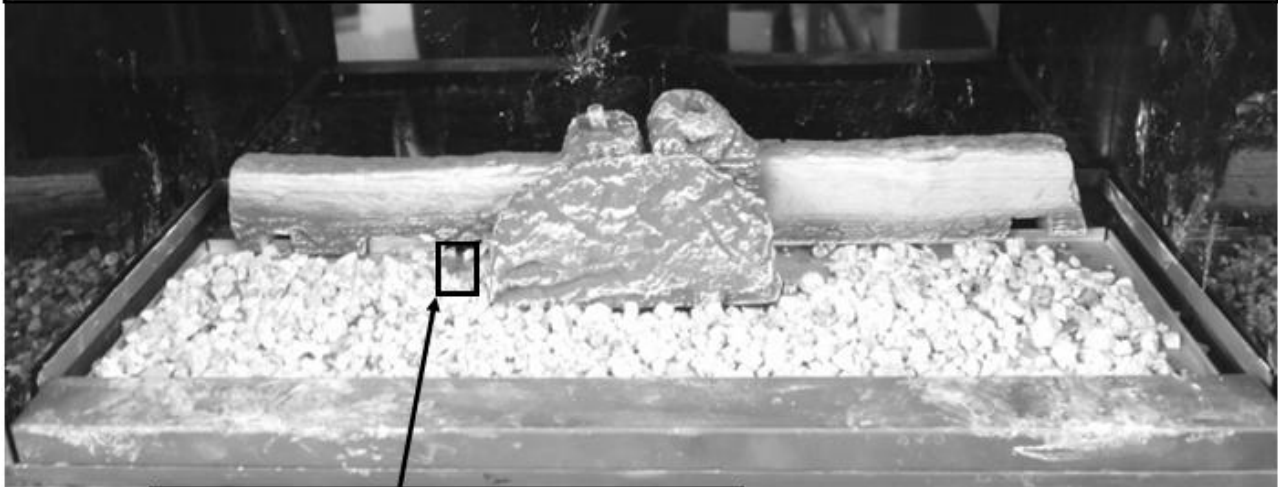

Avoid placing the vermiculite on the cross lighting ports

Place five nest off Embaglow in the are as as shown below

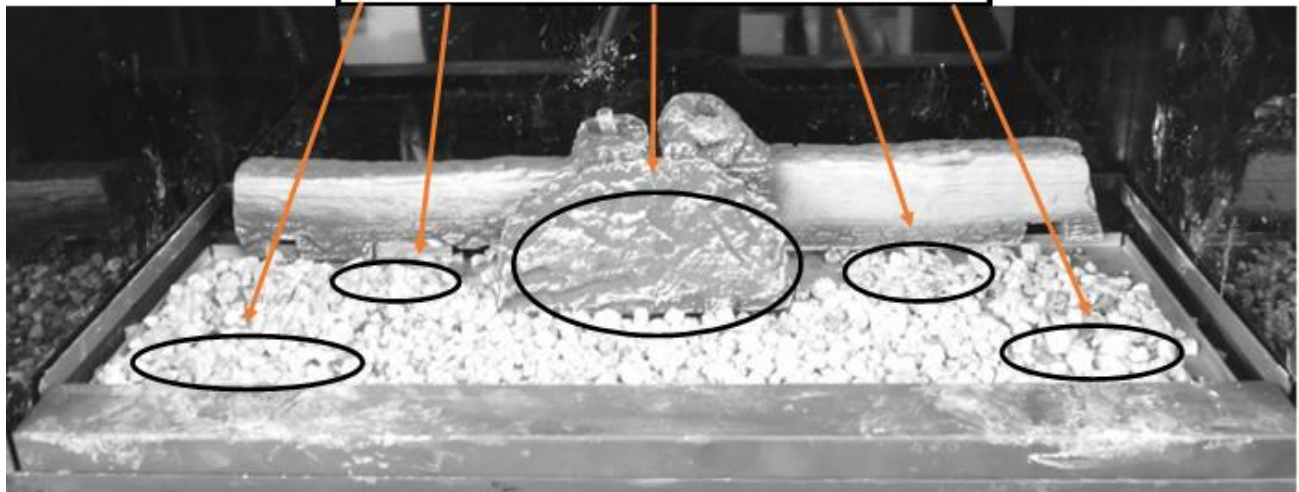

P11 USERS INSTRUCTIONS

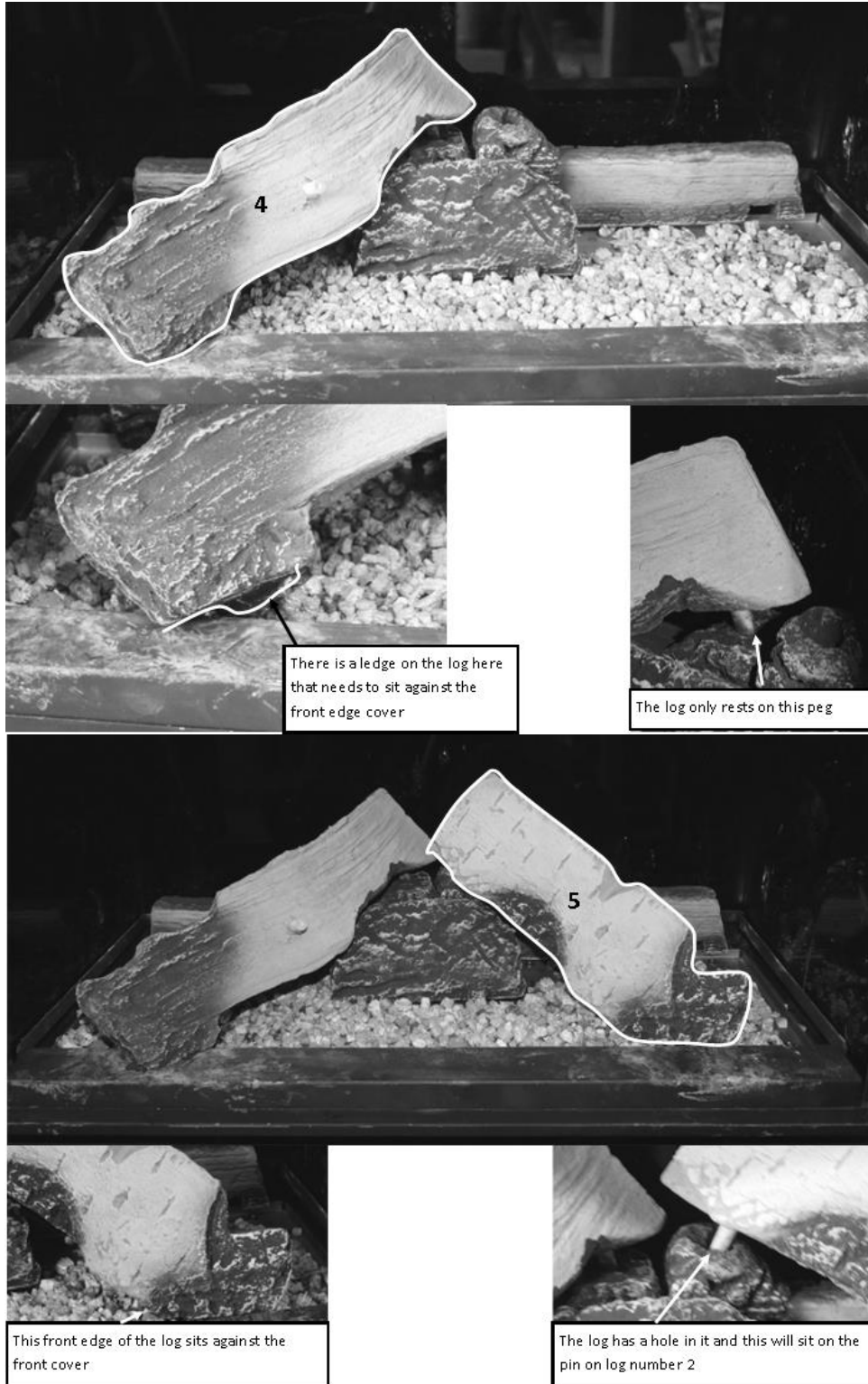

P11 USERS INSTRUCTIONS



P11 USERS INSTRUCTIONS

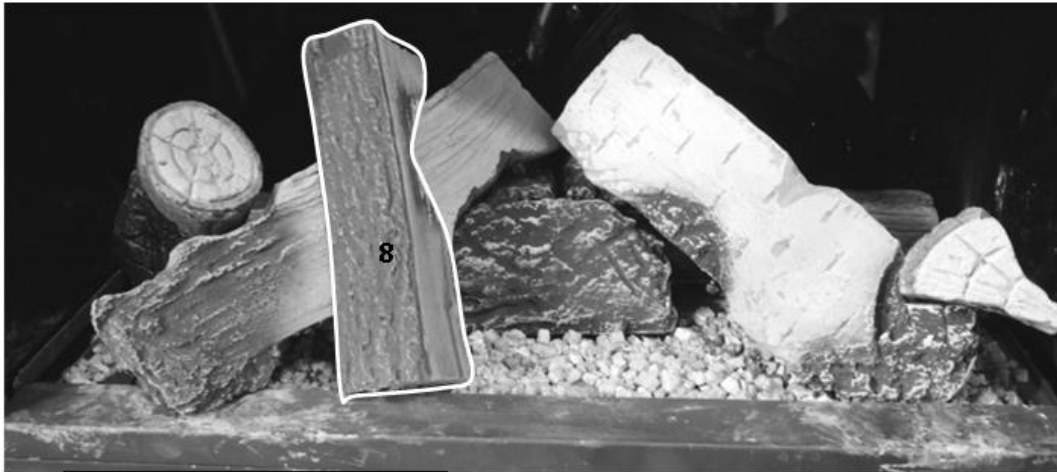

P11 USERS INSTRUCTIONS



This log is a triangle shape and sits in this groove on the log



P11 USERS INSTRUCTIONS

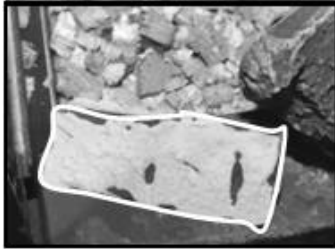

Technical Specification

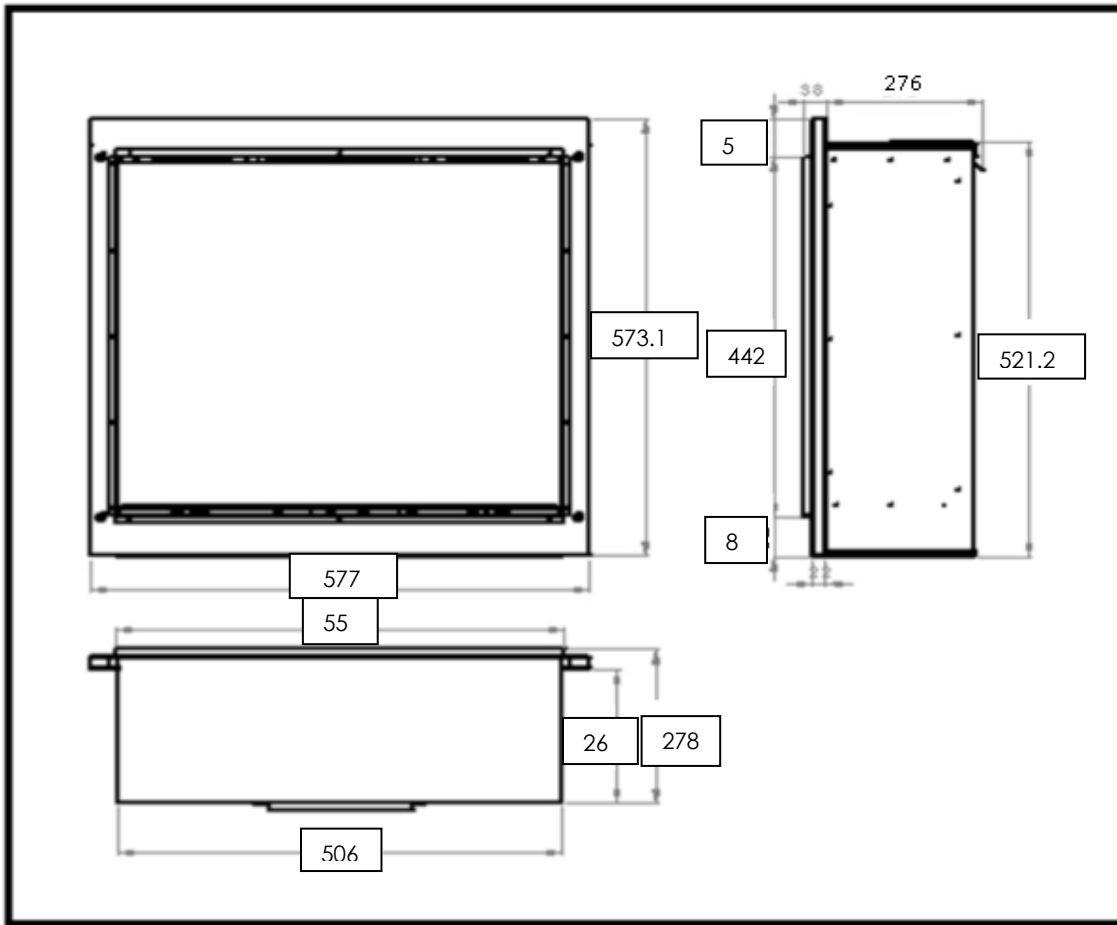

Model	Gas CAT	Gas Type	Working Pressure	Front Injector	Gas Input	NOX Class	Oxy Pilot	Country
P11	I2H	Natural Gas	20 mbar	Mrk 400	6.1 KW Gross	4	2900 NGR	GB, IE
P11	I3P	LPG	37 mbar	Mrk ???	6.0 KW Gross	5	9264 LPG	GB, IE

Efficiency Class 1

Gas Inlet Connection Size 8mm

Handset Replacement Batteries 2 x AAA 1.5V

Power Supply Type Plug – Input : 100-240 VAC 50/60 Hz, 0.2A

Note: - The efficiency of the appliance has been measured as specified in BS7977-1 2009+ A1:2013 and the net efficiency rate is 80.0% for natural gas & 79.1 for LPG. The gross calorific value of the fuel has been used for this efficiency calculation. Gastec have certified the test data from which it has been calculated. The efficiency value may be used in the UK Government's Standard Assessment Procedure (SAP) for energy rating of the dwelling. Within the appliance packaging will be an outlet restrictor, this is there to achieve the maximum efficiency. This, however, may not be fitted due to the flue underperforming.

Packaging Check List
1 x Glass Panel
1 x Boxed Fuel Bed
1 x Transformer Plug
1 x RF Handset
2 x AAA 1.5V Batteries

Siting the Appliance

Regulation and warnings

This appliance must only be installed in Great Britain and Eire.

The appliance is suitable for use on natural gas & LPG only.

When fitted in the GB the fire does not normally require purpose provided ventilation

In GB it is the law that all gas appliances must be installed by a competent person GAS SAFE registered installer, in accordance with the Current Gas Safe (installation and user) Regulations. All relevant parts of the local and national building regulations and all relevant recommendations of the following British standards. Failure to do so could lead to prosecution.

The following are relevant codes of practice and British Standards: -

B.S 5871

B.S 5440 Part 1 & Part 2

B.S 6891

This appliance must be installed to current versions of the above standards and include any relevant amendments to: -

The building regulations issued by the department of the environment.

The building standards (Scotland) (Consolidated) Regulations issued by the Scottish development office.

In Eire, the appliance must be installed by a competent person and installed in accordance with the current edition of I.S 813 document gas installation, the current building regulations and the current ETCI rules for electrical installation, if appropriate.

P11 INSTALLATION INSTRUCTIONS

Prior to installation ensure that the local distribution conditions (identification of the type of gas and pressure) and adjustment of the appliance are compatible G20 @ 20 mbar for natural gas.

The front of the fire act as a dress guard, conforming to BS 1945 (1971) and satisfies the heating appliance regulations (1991). However, a guard conforming to BS6539 (1984) must be used to protect young children, the elderly or infirm.

This appliance incorporates a safety device in form of an oxygen depletion system. It must not be adjusted or put out of operation. This is a non – serviceable item and must be exchanged as a complete assembly using only the original manufacturer's part.

A suitable proprietary fire surround with a 150 degree C minimum rating is required.

Class One

That is a conventional brick or stone chimney as used for a solid fuel appliance with an effective cross-sectional dimension of 225 x 225mm or a lined flue with a minimum diameter of 125mm. The chimney must have a minimum effective height of at least 3 metres. Any permanent flue restriction or variable damper are to be removed or locked fully open. The chimney should be swept prior to installation if it has previously been used with a gas appliance or if it is a new installation.

The P11 is designed to be fitted into a class one flue with a fireplace which will require a 50mm rebate. The other option is hole in the wall which can be plastered up to the edge of the fireplace frame or fitted with wall mounted non-combustible slips. The two methods will require different size apertures.

Builder's opening aperture size when fitted in conjunction with a 50mm rebated surround

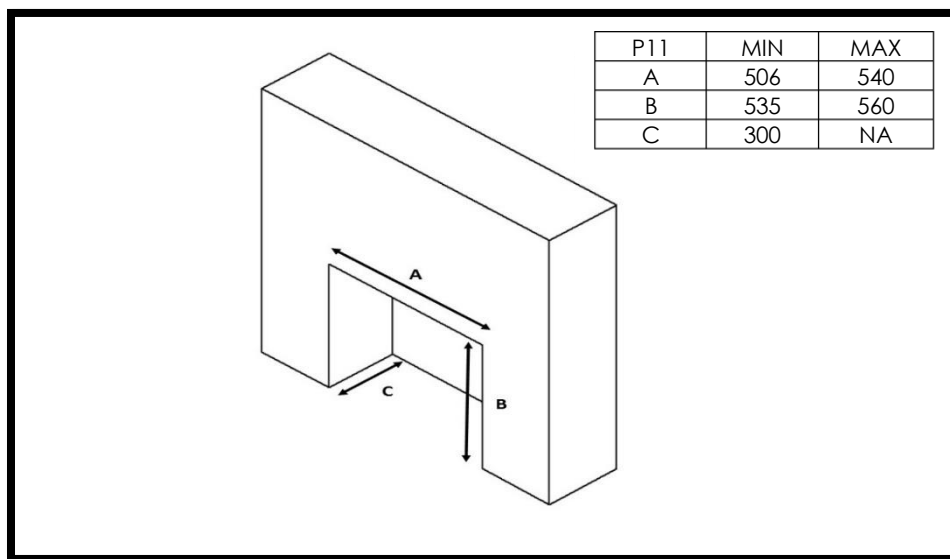

P11 INSTALLATION INSTRUCTIONS

Open the firebox aperture as of the sizes stipulated in the previous section (50mm rebated surround). Please note the fire box height from the floor may well vary dependent on the fireplace surround design. Check the fireplace details first. Slide the fire box back into the catchment area and secure the fire box against the front face of the chimney breast. Fit the fireplace frame to the fire box flange. The fireplace surround can now be constructed.

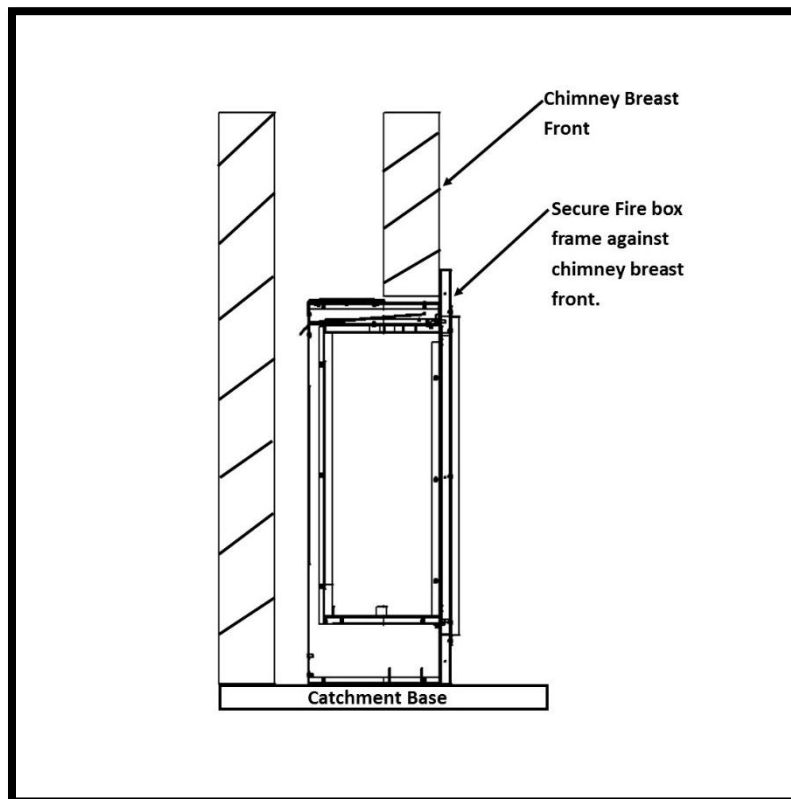

The P11 can be installed using three different methods when going hole in the wall.

A- Hole in the wall using noncombustible slips.

B-Dry lined hole in the wall.

C-Wet plaster hole in the wall.

P11 INSTALLATION INSTRUCTIONS

A- B-C / Builder's opening aperture size when fitting hole in the wall boarded edge or slips.

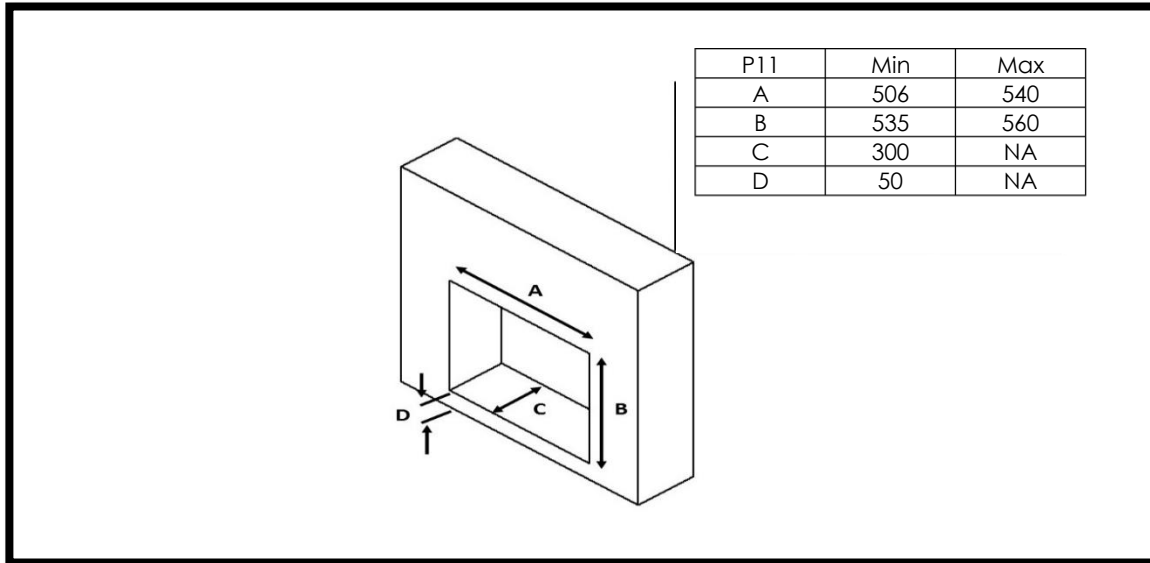

A-Hole in the wall using noncombustible slips.

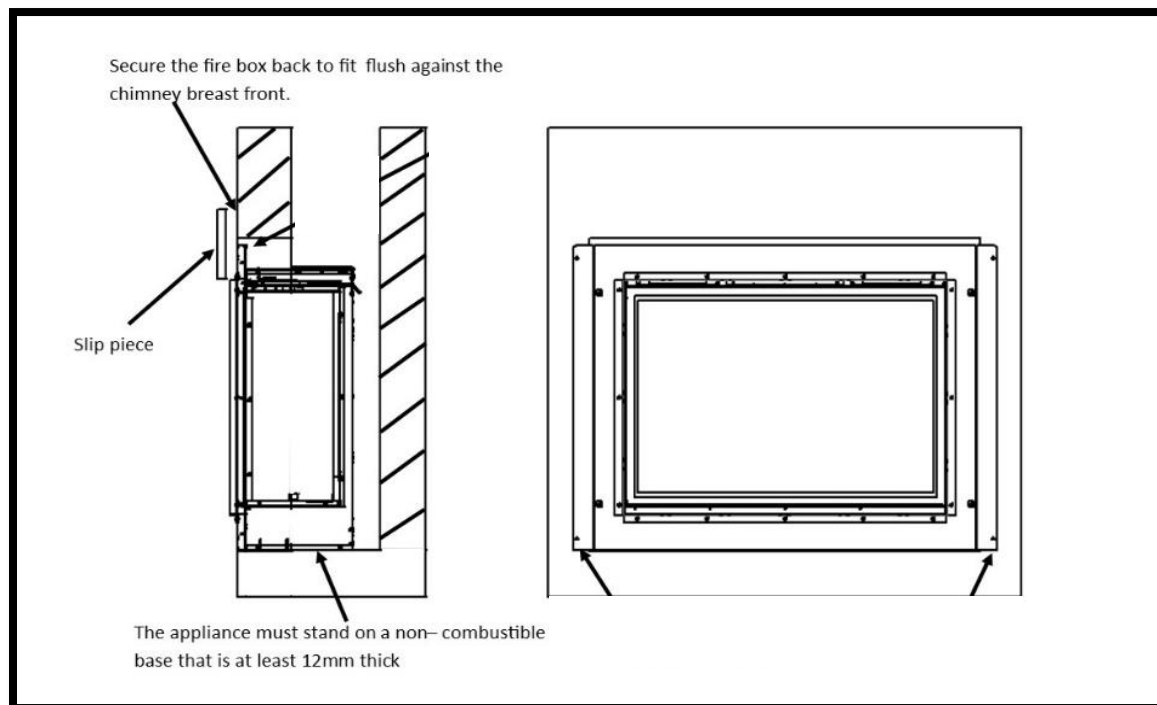

Using rawl plugs and wood screws retain the fire box via the holes in the Fireplace Frame. Noncombustible slips can now be fitted up to the edge of the fireplace frame.

P11 INSTALLATION INSTRUCTIONS

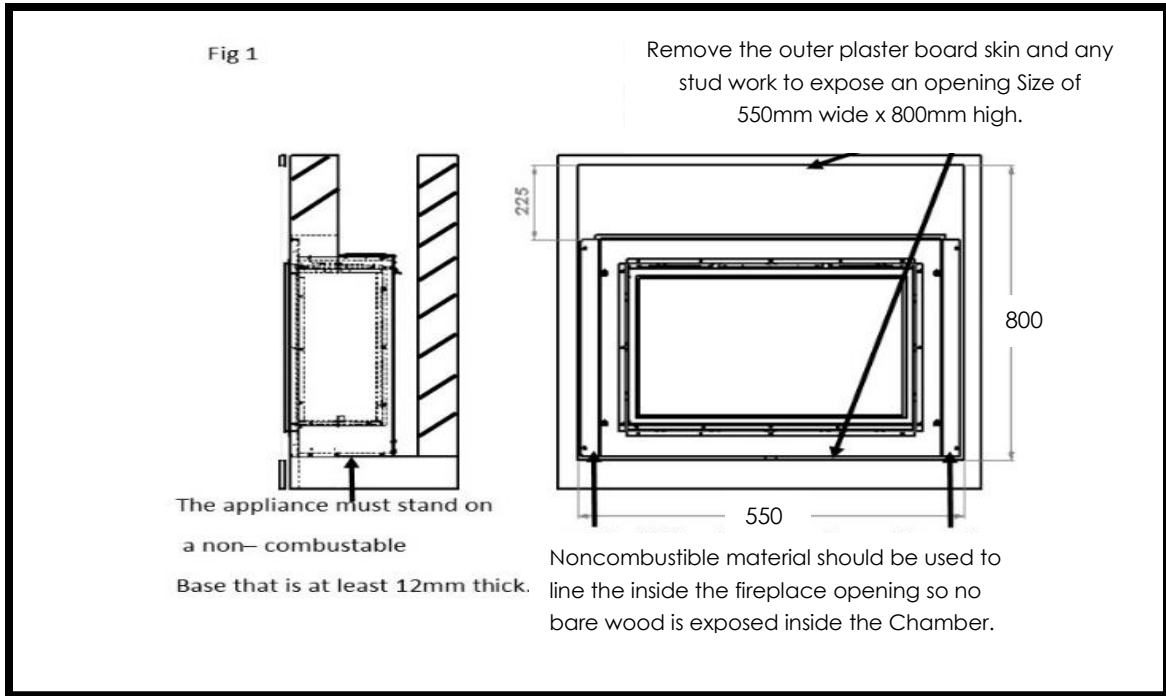

B-Dry lined hole in the wall.

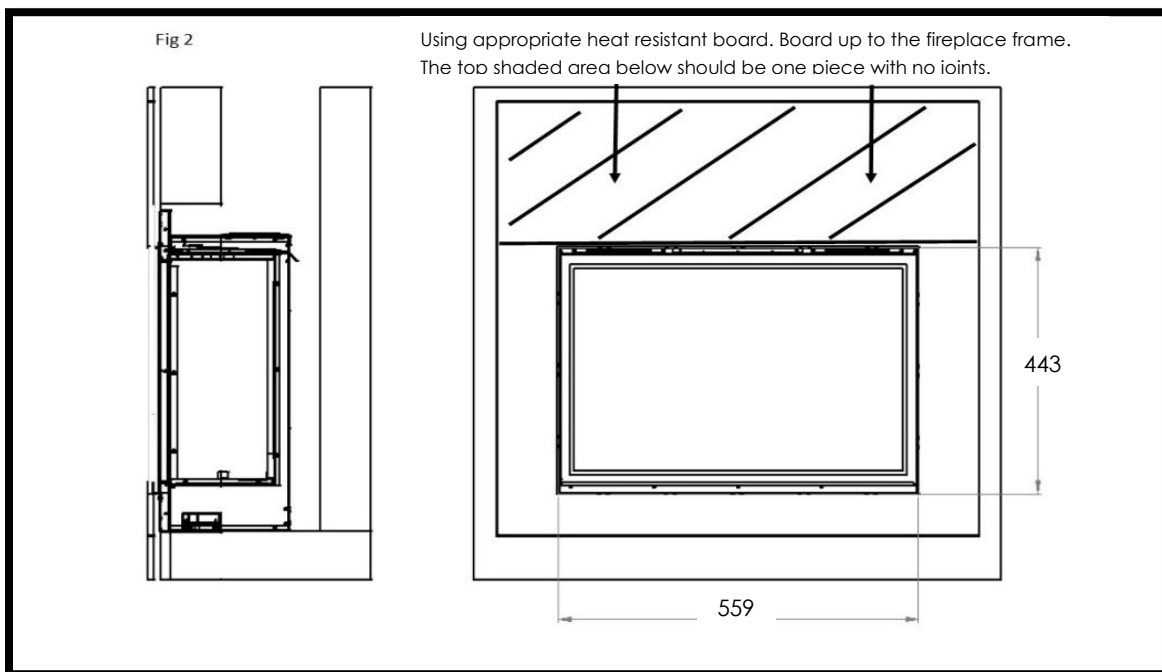

P11 INSTALLATION INSTRUCTIONS

Open the aperture size to accommodate the fire box as out lined at the beginning of the section. With the height of the opening established and support for the fire box in place, take out a further area of the plaster board lining to expose the inner brick work face of the chimney breast as out lined in Fig 1.

The exposed area should be 800mm from the base of the fire and 550mm in the width. Secure the fire box back against the inner brick work face of the chimney breast using rawl plugs and wood screws.

New plaster board can now be fitted to cover the exposed metal work, making sure that no plaster joints are positioned directly above the unit as highlighted in the Fig 2 as below.

C-Wet plaster hole in the wall.

When the chimney breast front has been finished using wet plastered method and the total thickness of the bonding plus finishing plaster is less than 12mm. The following method will need to be applied.

Fit the fire box using the guidance stipulated earlier in the section when fitting the fire box with noncombustible slips. With the fire box secured fit 15mm thick heat resistant board section to cover the complete front area of the chimney breast up to the forward projected edge of the firebox frame. Please note avoid any board joints directly above the unit.

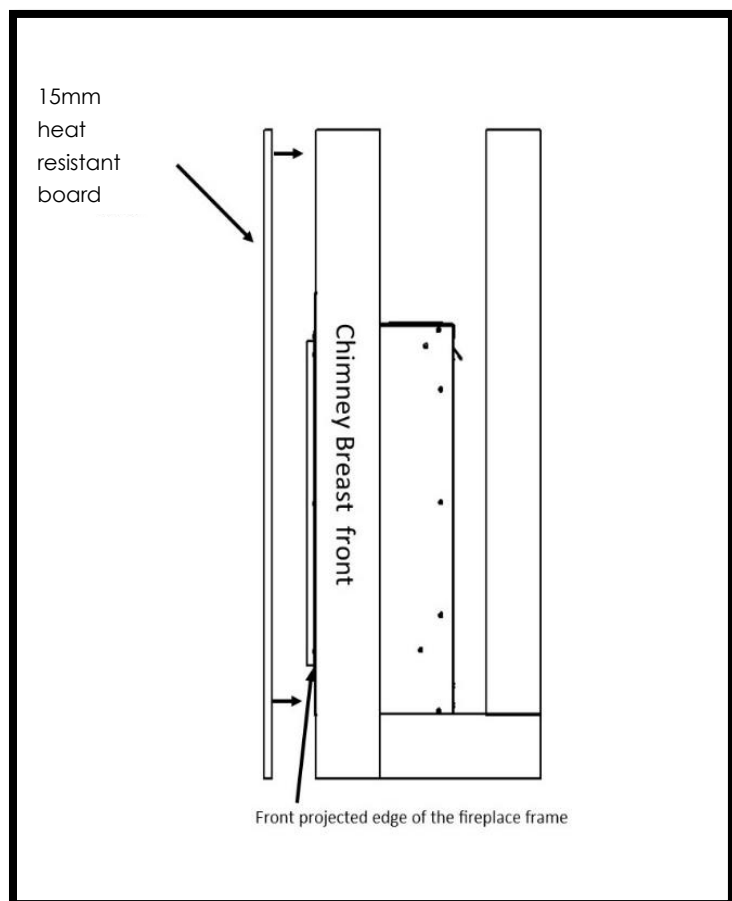

P11 INSTALLATION INSTRUCTIONS

Checking the flue fire opening and fire opening.

Check that the chimney conforms to the required specification as previously stated. Examine the condition and carry out any remedial work including removing any debris from the base. If the flue has been used for solid fuel it should be swept prior to installation. Prior to installing the appliance, a smoke test (using a bomb) should be carried out to check that satisfactory smoke clearance has been established. If all the smoke is not drawn into the flue, pre-heat the flue with a blowtorch or similar and retest. If there is any uncertainty examine for the cause and if necessary, seek expert advice.

When installing the appliance against a dry lined plasterboard wall ensure that the void between the plaster board and wall is sealed with a non-combustible material. No combustible material should be fitted inside the fireplace opening.

Installation with a flexible liner

The P11 is designed for installation within the masonry chimney with or without a flexible line. If the flexible liner option is required, the following two methods should be followed.

Method 1

A 125mm minimum diameter liner conforming to BS 715 may be used. Providing a suitable sealing plate is fitted to the base of the liner and the appliance does not restrict the opening into the liner. Ensure a smooth lead into the flue way and no combustible materials are used. A void of 50mm must be maintained from the top of the firebox into flue.

Method 2

Using the flexible liner Top Outlet Assembly (Optional Part). Again, using a 125mm minimum diameter liner conforming to BS 715, route the flexible liner within the masonry as of the requirements stipulated by the liner manufacturer.

Attach the Top Outlet Assembly to the liner using a suitable fixing.

Important Info

When fitting to a 125mm Flue, the 7" restrictor must be removed, a 5" restrictor which is packed separately may be fitted in its place if satisfactory spillage test is achieved. If the spillage test fails, the Restrictor Cover Plate must be fitted instead, and a spillage test done.

P11 INSTALLATION INSTRUCTIONS

IMPORTANT !!!

The Internal 7" Restrictor Plate must be removed when fitting to a 125mm Flue Liner. The Restrictor Plate is accessed from inside the top of the inner box.



Undo the two M4 nuts, the Restrictor Plate should fall away as shown.



P11 INSTALLATION INSTRUCTIONS

The 7" Restrictor may be replaced with the 5" Restrictor when fitting to a 125mm flue as long as satisfactory spillage test is achieved. If not, the Restrictor Cover must be fitted.

5 inch Restrictor seen below



The Restrictor Plates or Cover should be fitted and held in place with the two x M4 nuts making sure they are tight, as shown.



P11 INSTALLATION INSTRUCTIONS

Remove the Top Outlet Cover from the top of the box.

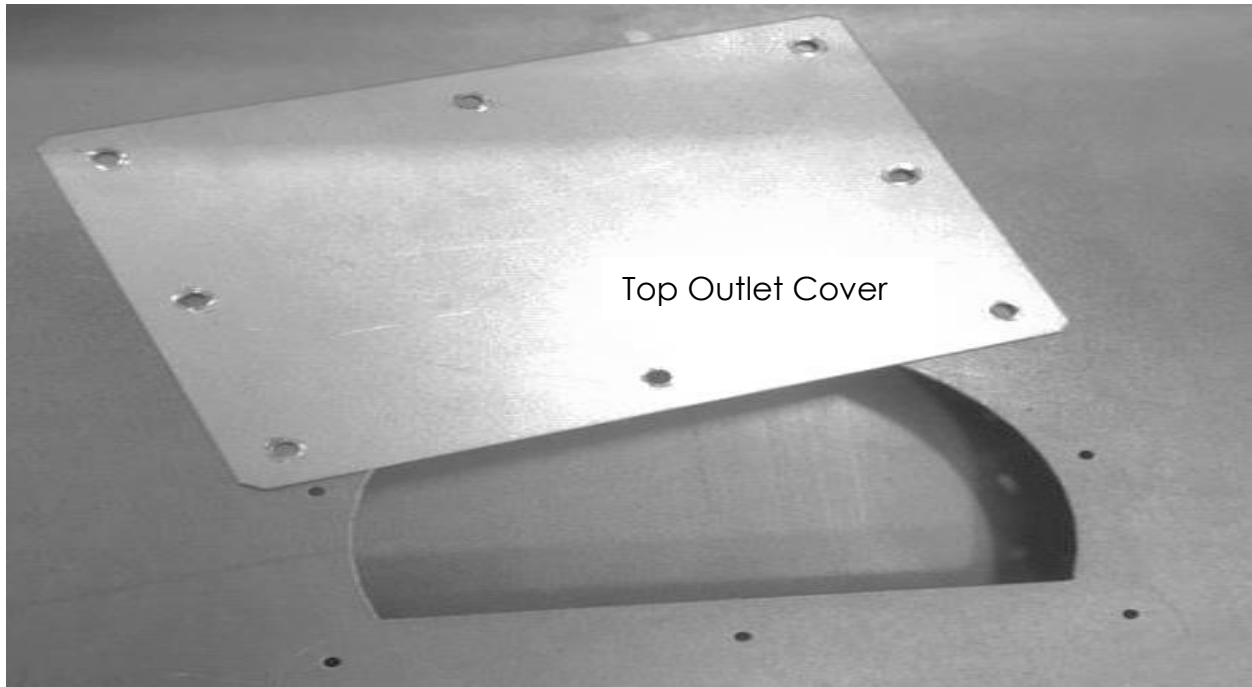

The Outlet Assembly Guides are provided in the kit, shown below.

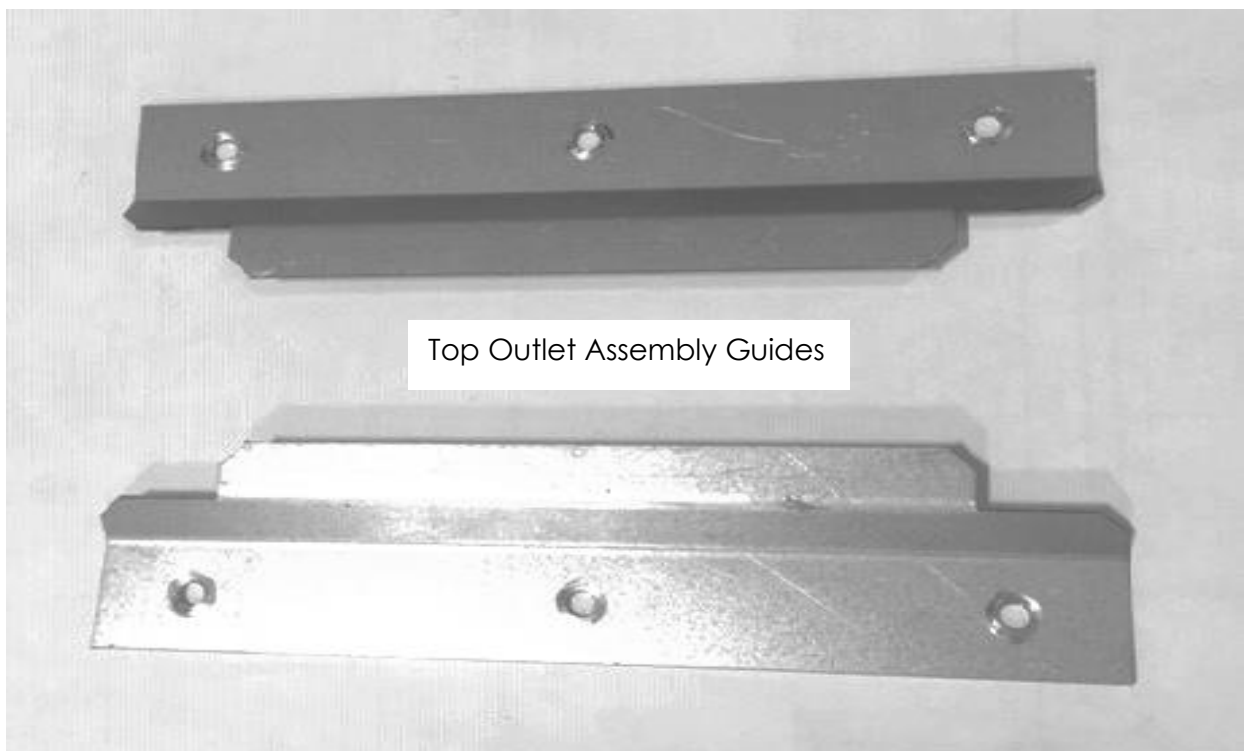

P11 INSTALLATION INSTRUCTIONS

Fit the Guides as shown below, using 6 x Self Tapping screws as shown below.

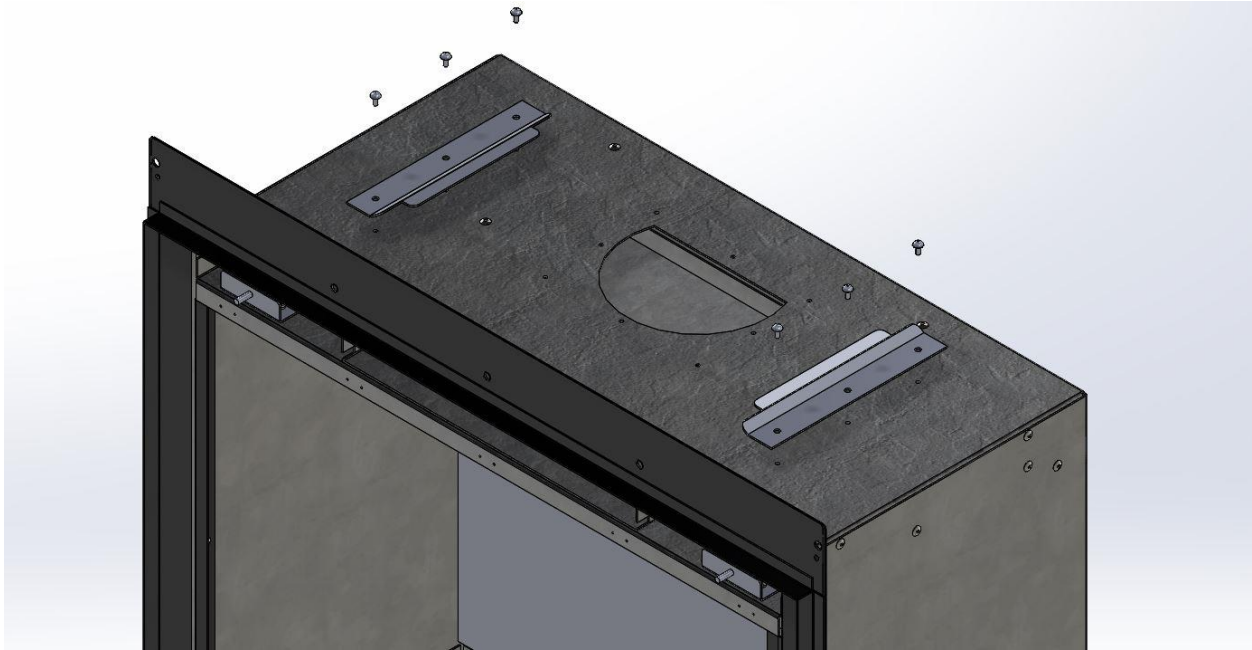

Offer the fire box assembly within the masonry aperture at the same time guiding the Outlet Assembly within the guides situated on the top of the fire box (Please see Fig 2). Slide the Outlet Assembly towards the front flange and secure using the three Self Tapping screws provided within the Outlet Assembly kit.

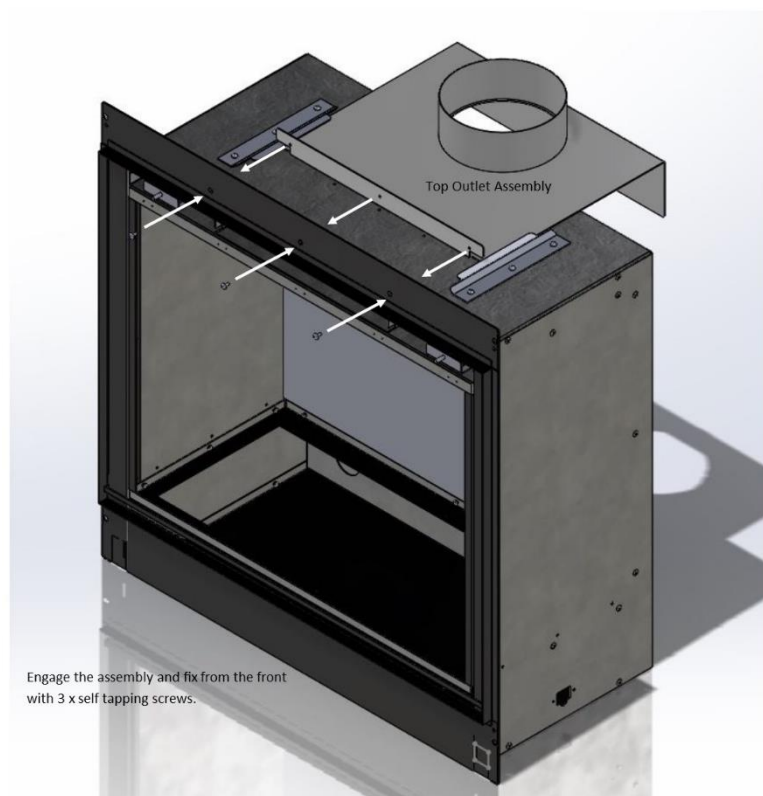

P11 INSTALLATION INSTRUCTIONS

Gas supply routing.

Check the gas run to assess that the gas supply can provide the required amount of gas and is in accordance with the rules in force.

Soft copper pipe can be used to install the appliance. Soldered joints can be used only externally of the appliance.

The appliance is supplied with a factory fitted isolation device to allow for an 8mm copper connection. No further isolation point is required.

The new gas line must be purged of any debris, prior to final connection to the appliance.

Gas inlet isolation device is located on bottom left-hand side of the fire box, the gas supply entry point is positioned at the rear bottom on left hand side. With the appliance fixing kit is a 35mm round seal (Please see fig 3), this should be cut and fitted over the 8mm copper at the point the gas supply entry into the appliance assembly. The burner assembly will need to be removed by removing the two retaining screws. With the screws removed lift the burner assembly up on the left-hand side and remove from the burner carrier. (Special care must be taken not to damage or dislodge the burner silencer located on the right-hand side.

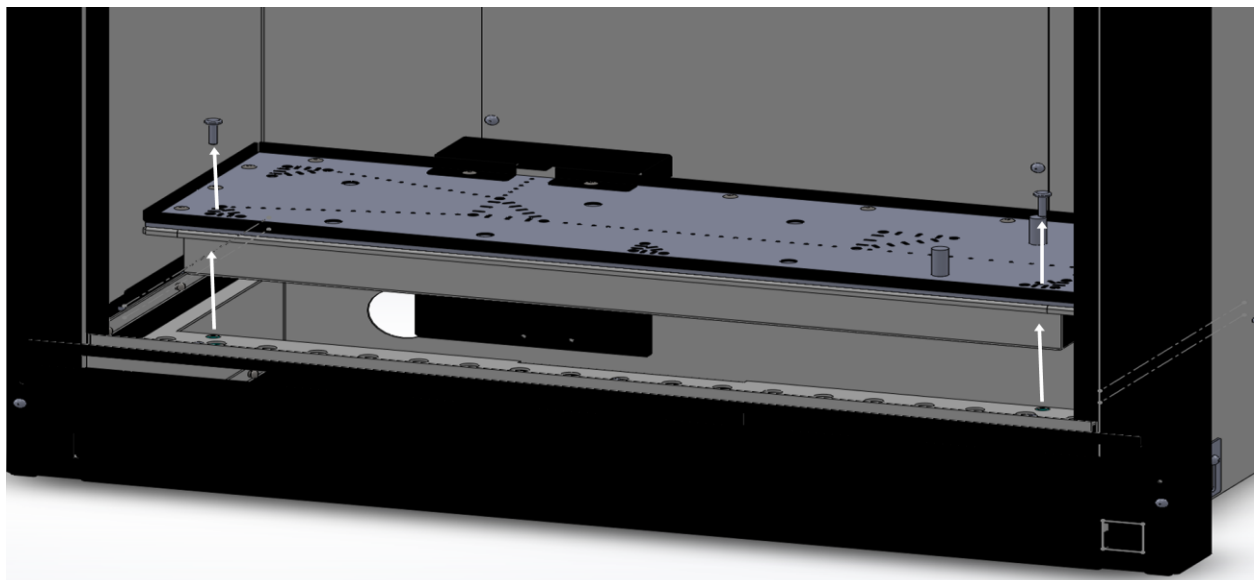

P11 INSTALLATION INSTRUCTIONS

The gas inlet isolation device must be angled to allow access to the grub screw and gas test nipple.

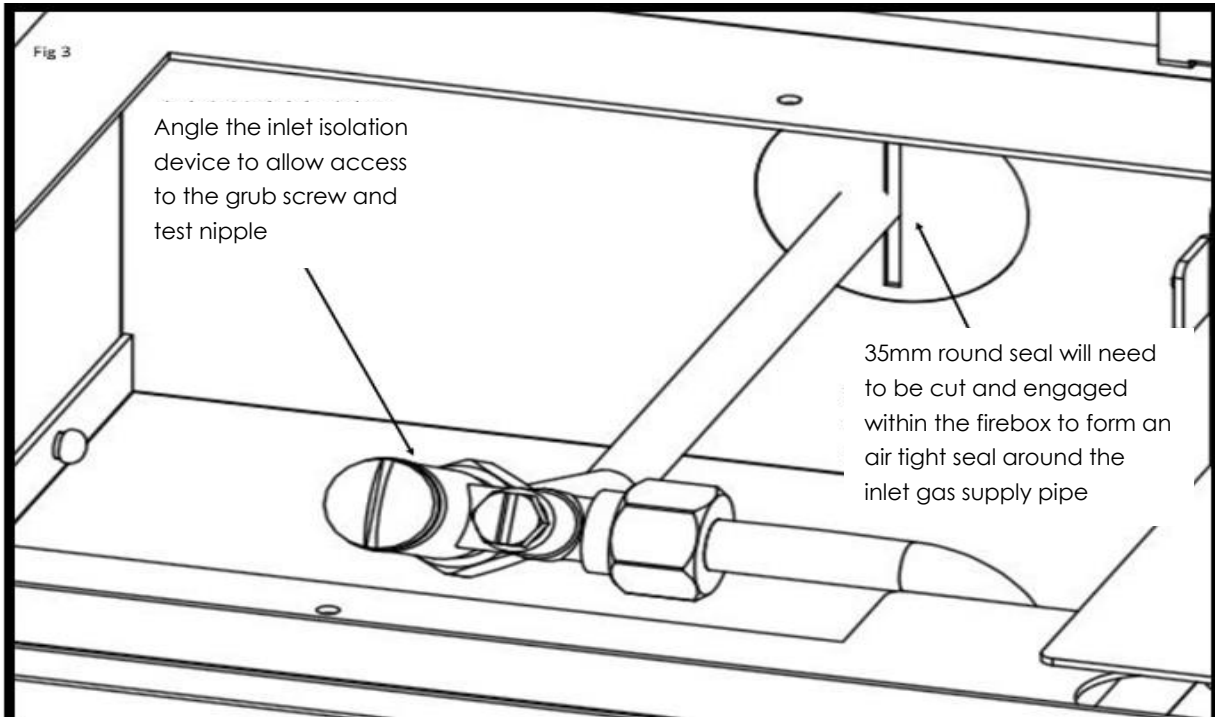

P11 INSTALLATION INSTRUCTIONS

Power lead routing

The power supply for this appliance is provided via AC power adaptor 230 VAC. The main cable terminates at the rear Right hand side of the fire box. The length of the cable provided with the appliance is 1.65 metres. Care must be taken when siting the fire box not to trap the exposed main cable within the builders opening.

The cable can be routed using the following two methods,

Method 1

Passing the cable through the side of the chimney breast. It is good practice to run the cable within a sleeve of at least 15mm internal diameter, sealing the sleeve using a suitable sealant at the point the sleeve / cable terminates the chimney masonry.

Method 2

Remove a channel out of the outer skin of the Dry / wet plaster of the chimney breast up to the main power point. Again, it is good practice to run the cable within a sleeve of at least 15mm internal diameter.

With power points that exceed the 1.65 metre distance, an optional 2.0 metre extension cable is available Part No 7147.

The cable system consists of retro fitting plug sockets which offers the following options. (Please see figure 5).

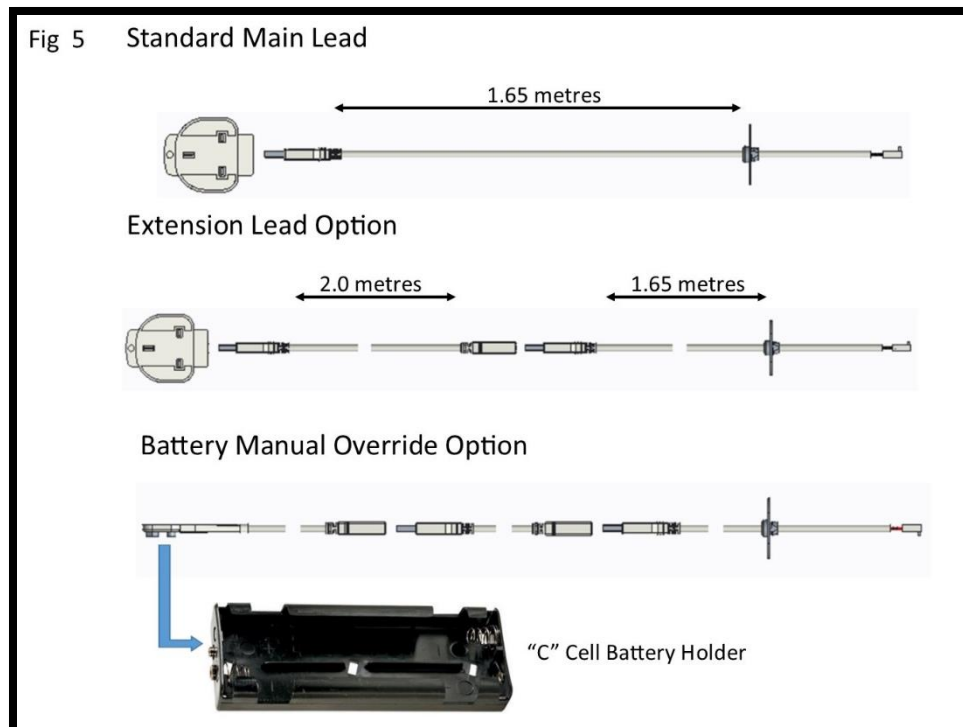

P11 INSTALLATION INSTRUCTIONS

The battery manual override option is a backup supply in case of a power failure / power cut to the property. The battery holder and adaptor lead sold separately. (Please note that the “C” cell batteries are not included). It is good practice to demonstrate the battery option to the customer during the commissioning process.

Fire Box Installation

Note: - When installing the appliance with a 3 inch (75mm) rebated surround the optional 45mm spacer frame will be required.

The fire box assembly can be retained using the following two methods.

Secure the firebox when fitted with 1 inch (25mm) rebated surround or Hole in the Wall.

Attach the Silicone seal to the rear of the Fire Box Flange, then the Fireplace Frame fits by sliding the two bottom Location Tabs into the slots on the fire flange, then fixing back through the 4 x 6mm holes using suitable rawl plugs and wood screws retain the fire. Noncombustible slips or wet plaster can now be fitted up to the edge of the Fireplace Frame.

(figure 6 below is for illustration purpose only)

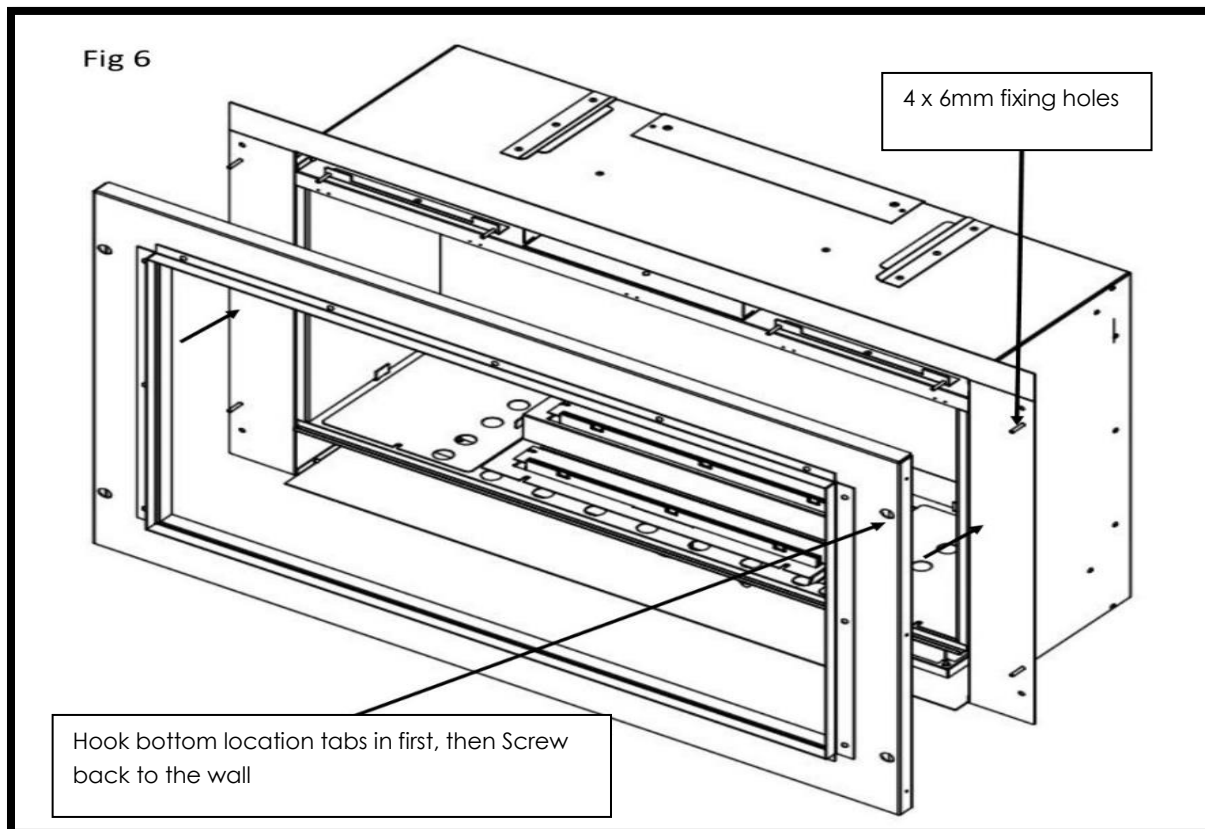

P11 INSTALLATION INSTRUCTIONS

Commissioning the Appliance

Checking gas soundness and running pressure.

Turn on the supply to the appliance and check for soundness in accordance with the current codes of practice.

Turn off the gas supply at the external isolation valve.

Remove the pressure test point screw from the inlet elbow and connect the pressure gauge.

Turn on the gas to the appliance at the isolation valve.

Light the appliance as described in the user instruction section. Page 5 turn on (startup).

Check the inlet pressure is 20 mbar +/- 1.0 mbar for natural gas & 37mbar +/- 1.0 mbar for L.P.G. with other appliances running.

Turn off gas supply, at the isolation valve. Disconnect the pressure gauge and replace the pressure test point screw.

Turn on the appliance and check the pressure test point for soundness with detection fluid. Reassemble.

Fuel Bed Layout.

Fuel bed layout should be fitted using the guidance stipulated on pages 7 - 12 of the User Instruction section.

Fit Glass Panel.

Due to transit protection, the glass panel is packed with a protective sleeve within the packed appliance. Special care should be taken when removing the glass panel from the packing. The top fixing is attached to the fire box via 2 x M4 fixing nuts. Remove the nuts and remove the top fixing bracket. (Please see the user instruction section on page 6).

Locate the glass panel within the bottom retaining slot and push back against the seals. (Please see Fig 11).

Position the top fixing bracket over the top edge of the glass panel and slide over the two M4 studs.

Using the 2 x M4 nuts previously removed. Tighten the top glass fixing using the nut spinner provided with the appliance (be careful not to over tighten as this will crack the glass) and refit Glass Fixing Cover.

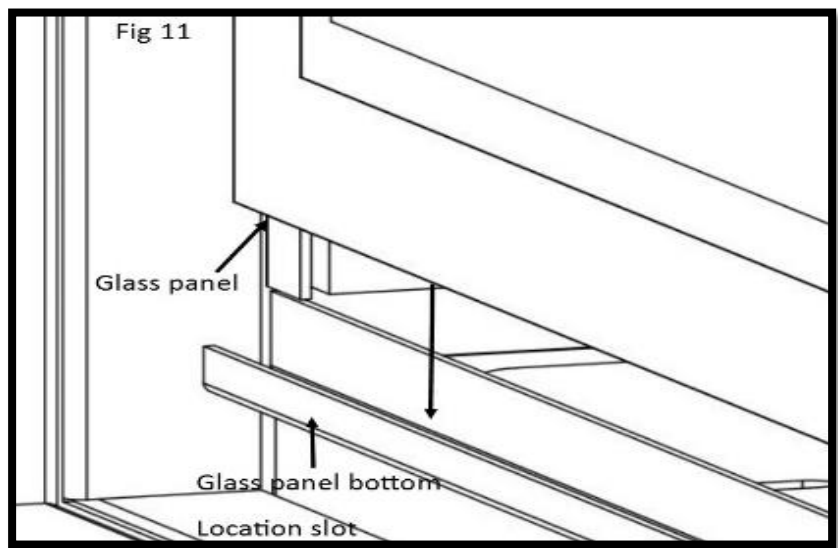

P11 INSTALLATION INSTRUCTIONS

Spillage Test Procedure.

Light the appliance on maximum setting.

Close all the doors and windows.

After five minutes fit the smoke match within match holder and position as illustrated in Figure 13 with the head of the match just inside the inlet air channel.

Run the match along the edge of the inlet air channel. All smoke must be drawn into the inlet channel if the spillage test is satisfactory.

If spillage occurs wait a further five minutes and repeat the test.

Repeat the test with doors open and with any extractor fans in other rooms in operation.

If spillage is detected the cause must be discovered and the fault corrected. If the fault cannot be corrected, disconnect the fire from the gas supply and seek expert advice. Spillage can be caused by a restriction in the flue system, down draught, or insufficient ventilation into the room where the fire is installed.

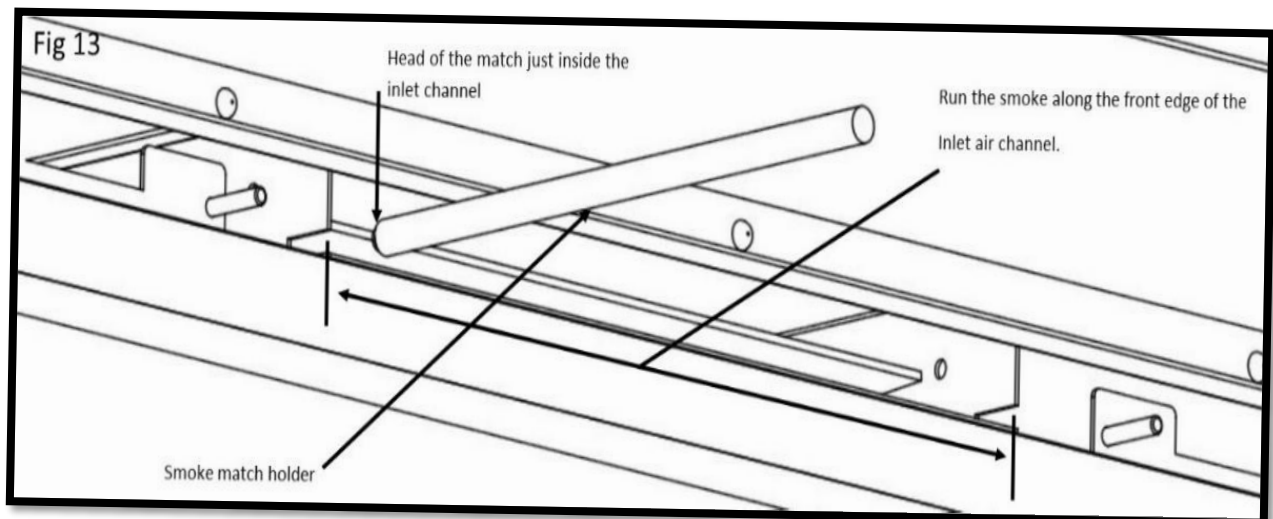

P11 INSTALLATION INSTRUCTIONS

Advise The Customer.

The glass front of this fire acts as a dress guard conforming to BS 1945 (1997) and satisfies the heating appliance regulations (1991) however; a fireguard conforming to BS6539 (1997) must be used to protect young children, the elderly, or infirm.

During initial "burn off", an odour may be evident during the first few hours of use. This is due to the surface coating on the metal work "burning off". The odour produced is harmless and will disappear after a short period of time.

Any debris should be cleared from the appliance.

The appliance should be serviced annually by a Gas Safe registered engineer in accordance with the Service instruction section.

Point out the position of the power source for the appliance, plus demonstrate using the additional battery holder and adaptor lead, the battery backup option. ("C" cell batteries not included within this appliance).

Demonstrate the lighting and extinguishing procedures to the user and the removal and refit of the glass panel for cleaning and the fitting of the battery backup kit.

Hand this instruction over to the user along with the M4 nut spinner for the removal of the glass panel.

Please be aware that the non-reflective glass may in some lights and from some angles have a blue tinge to it this is perfectly normal. Also be aware that if the glass liners are fitted in the fire with the non-reflective glass, you will still have a reflection in the glass liners.

Annual Service Requirement.



General

Servicing should be carried out annually by competent person whose name appears on the gas safe register. All Gas Safe engineers should possess an ID carrying the logo below.

Before commencing any service or replacement of part, turn off the gas supply to the fire. After servicing check for gas soundness.

When ordering spare parts please quote the appliance name and serial number.

Check for debris

At least once a year check for debris in the catchment area behind the fire and in the flue way. To undertake this, check the following procedure should be followed.

Lift up and remove the Glass Fixing Cover.

Remove the 2 x M4 nuts fixing the glass clamp to the glass panel. (See Page 6).

With the nuts removed, pull the glass clamp clear of the two studs.

Finally lift the glass panel out of the bottom glass fixing.

Remove the log shapes and Vermiculite.

Remove the two-side liner fixing bracket LH & RH which are situated in the roof of the inner fire box assembly.

Carefully remove the LH & RH side panels whilst holding the rear panel in place.

Remove the rear panel from within the fire box.

Finally remove the eight screws from the inner and outer inspection covers.

(Please see figure 1 on next page)

With the covers removed. The catchment area at the rear of the fire box can now be inspected for debris. With the aid of a mirror via the back of the box check the path of the flue for any restrictions.

Re-assemble in reverse order and lay fuel bed as shown on pages 7 - 12.

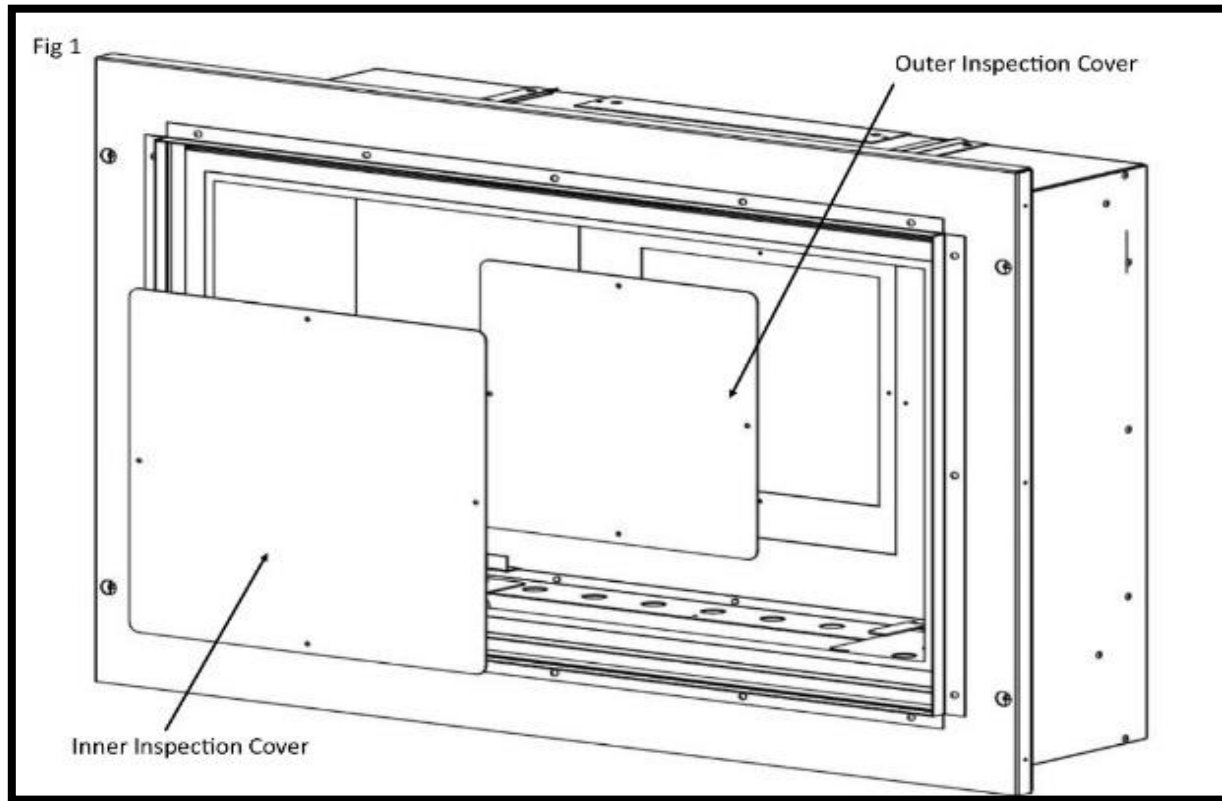

Pilot Linting

It will be necessary to remove the burner assembly from the fire to clean the pilot head & pilot aeration hole, this should be carried out by a Gas Safe registered engineer.

Check the pilot aeration hole for linting, use a vacuum clearer nozzle taking care not to damage the pilot head. Do not blow compressed into the pilot as this can lodge debris in the pilot body.

Electrode Gap

The electrode gap should be 4mm from the tip of the thermocouple probe head to the end of the electrode wire.

Spillage test

Follow the procedure stipulated on page 30 of the installation instruction section.

P11 SERVICE / FAULT FINDING INSTRUCTIONS

Fault Finding Charts

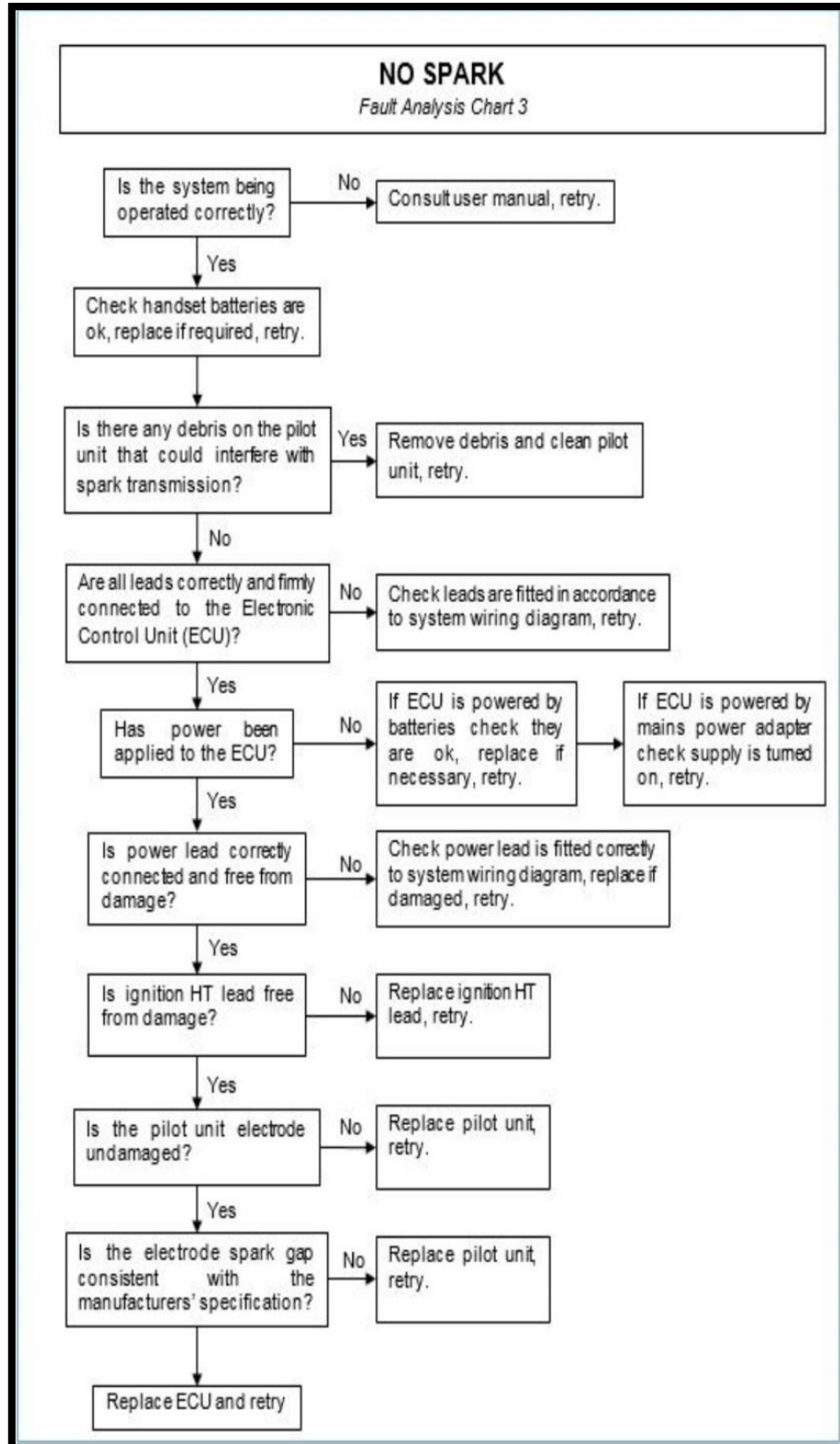

P11 SERVICE / FAULT FINDING INSTRUCTIONS

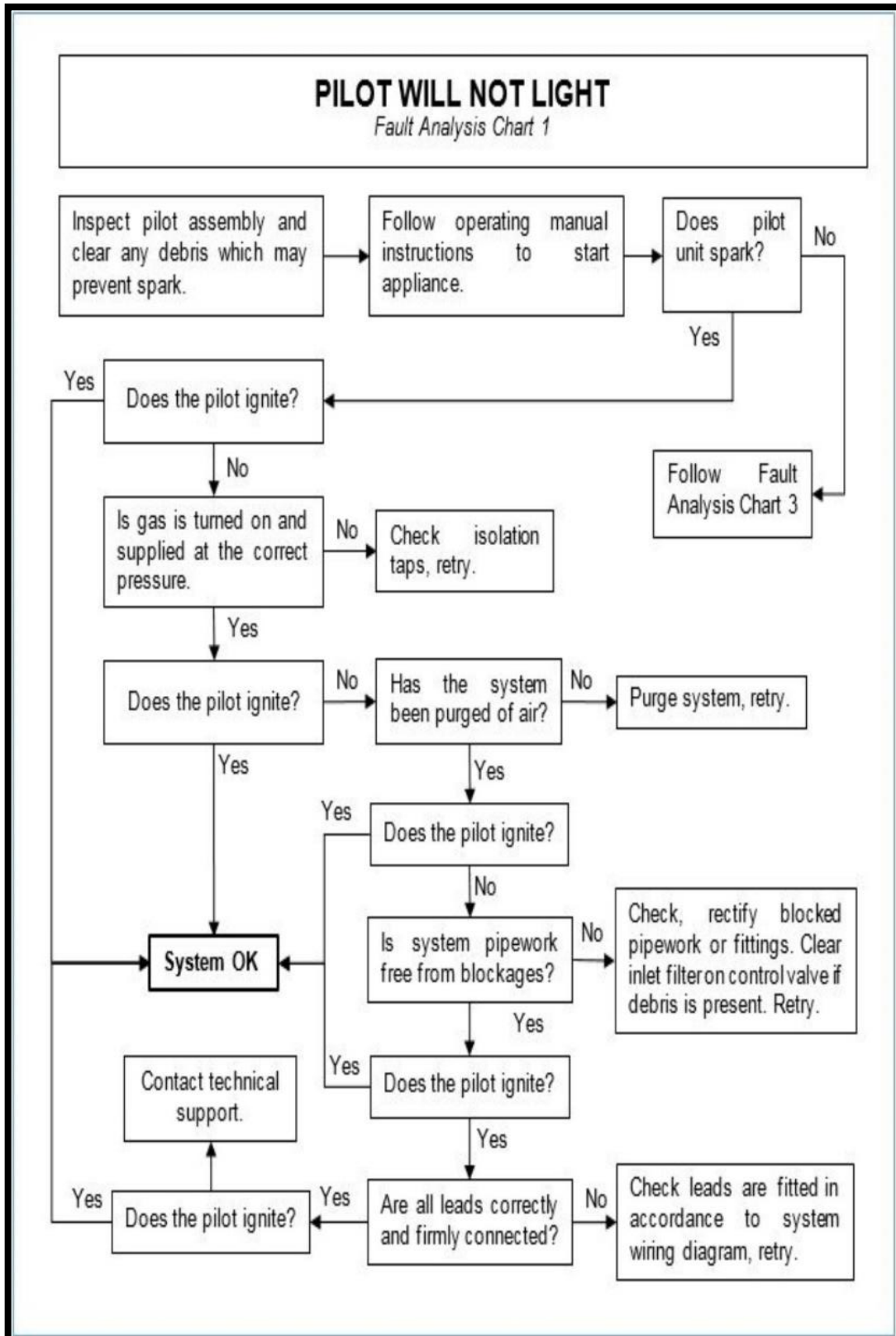

P11 SERVICE / FAULT FINDING INSTRUCTIONS

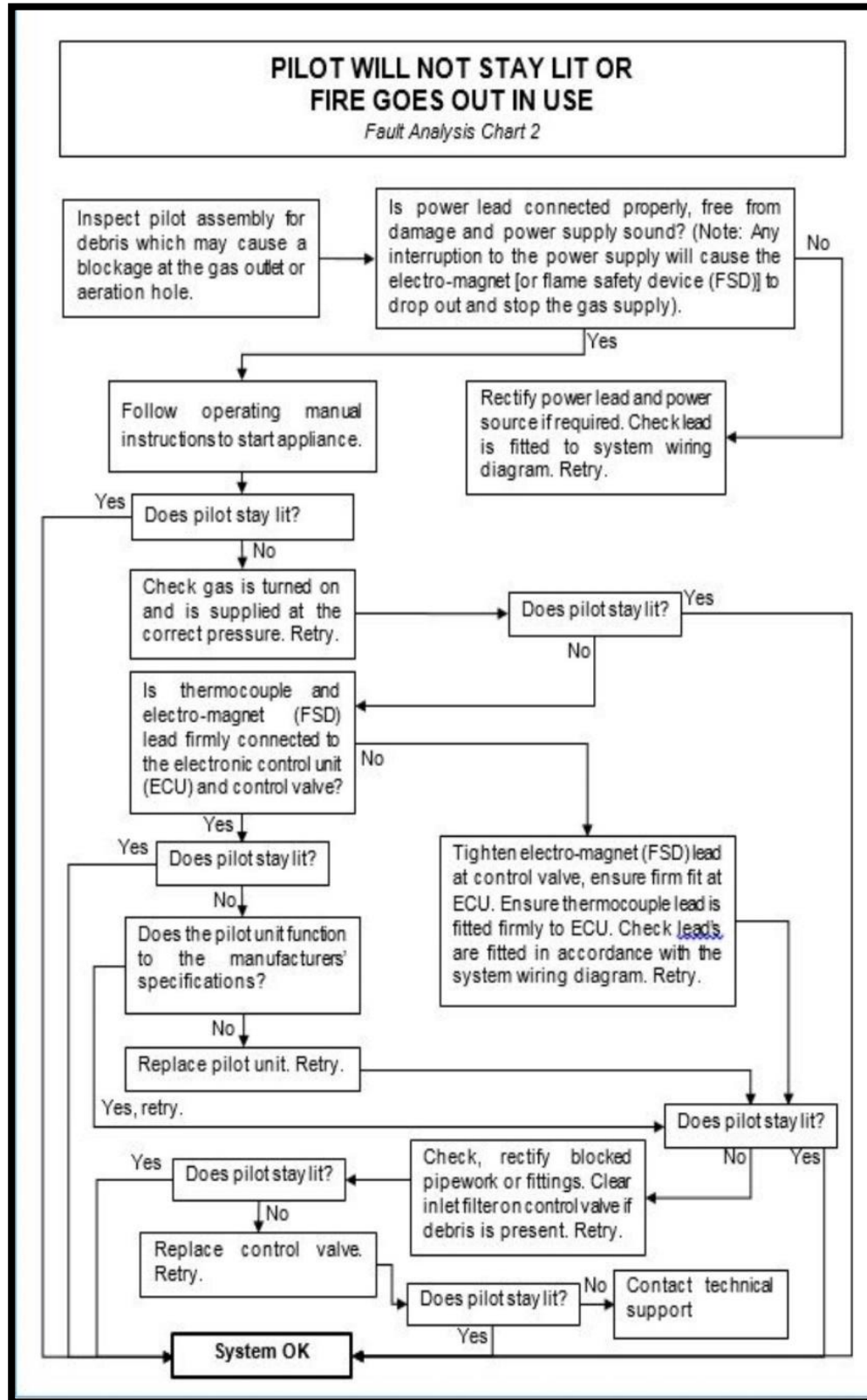

P11 SERVICE / FAULT FINDING INSTRUCTIONS

Wiring Diagram

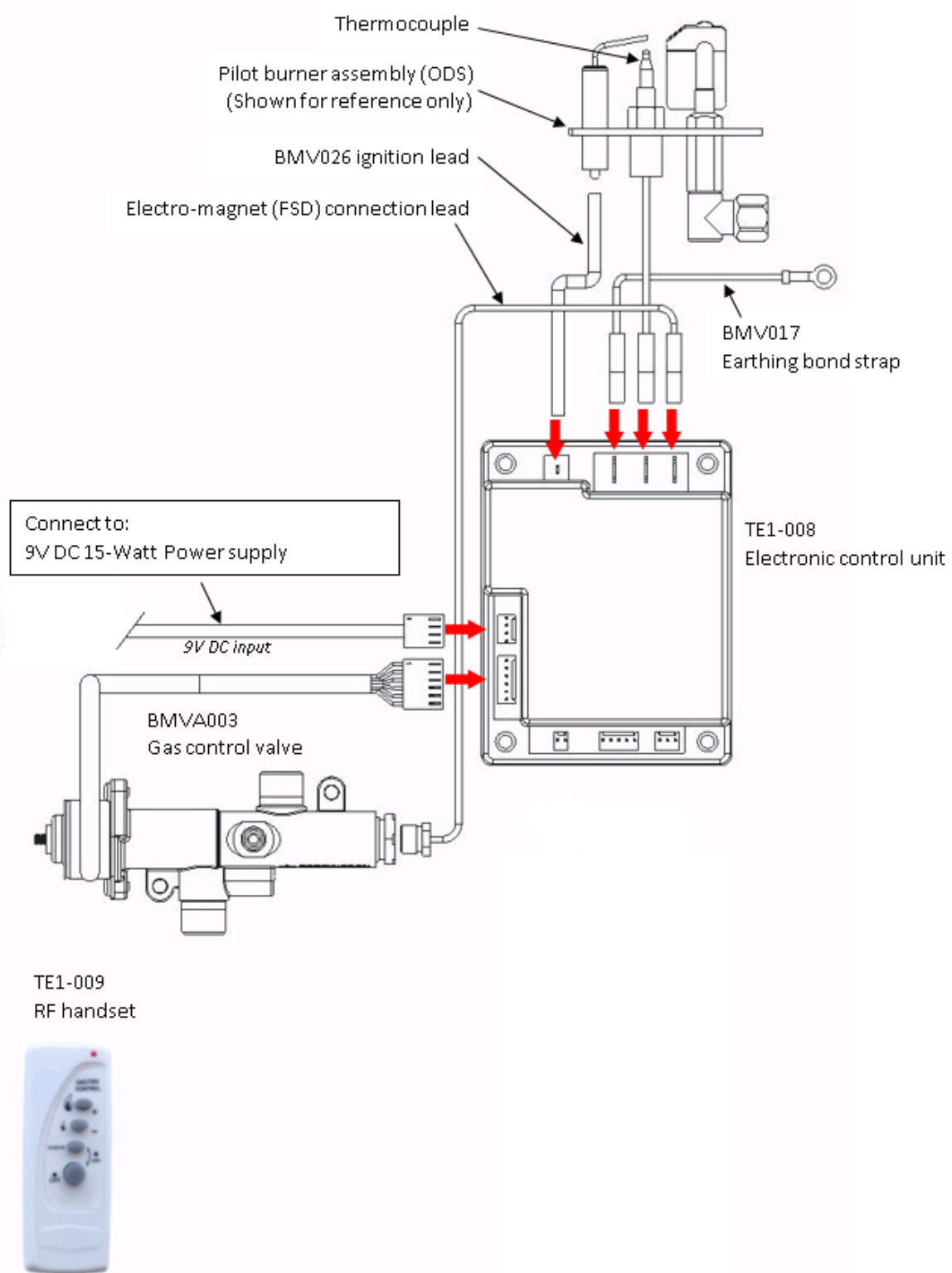

Maintenance

To Remove the Burner Carrier Assembly

Remove Glass Fixing Cover and the Glass Panel as described on page 6 of the users instruction section.

Remove the Loose shapes.

Remove the two screws retaining the burner Assembly.

Shut off the restrictor elbow and disconnect the 8mm inlet nut.

Switch off the mains supply from the main supply plug socket.

Undo the M3 nut retaining the ECU unit and disconnect the mains supply cable connection.

Take out the six screw retaining the burner tray assembly and lift out of the fire box shelf taking care not to damage the panels.

P11 MAINTENANCE INSTRUCTIONS

Replacement of The Gas Valve

Follow the sequence to remove the burner carrier assembly.

Disconnect the thermocouple from the rear of the gas valve.

Undo the three compression nuts securing the pipes to the gas valve and remove the two M4 nuts fixing the valve to the valve mounting brackets.

Clean, service or replace the gas valve.

Re-assemble in the reverse order.

Turn on the gas supply, check for soundness and re-commission the appliance.

Replacement of the Injector

Follow the sequence to remove the burner carrier assembly.

Undo the compression nut on the supply pipe.

Remove the two screws retaining the burner assembly to the carrier and lift away from the injector.

Unscrew the locking nut holding the injector and silencer bracket on the burner carrier.

Remove injector from assembly. Clean or replace injector.

Re-assemble in reverse order.

Replacement of the Oxy-Pilot Assembly

Note: If the pilot assembly is replaced it must be replaced by an identical unit from the same manufacturer and replaced as a complete unit.

Follow the sequence to remove the burner carrier assembly.

Undo the compression nut on the supply pipe at the pilot.

Carefully pull off the ignition lead.

Disconnect the thermocouple at the end of the gas valve.

Remove the two fixing screws attaching the assembly to burner carrier.

Re-assemble in the reverse order.

P11 MAINTENANCE INSTRUCTIONS

Replacement of the Burner Assembly

Remove the glass panel as described on page 6 of the user's instruction section.

Remove the Loose shapes.

Undo the two fixing screws retaining the burner assembly with the carrier.

Lift the burner up from the Left-Hand side, clear of the silencer and injector tip.

Clean or replace the burner assembly.

Re-assemble in reverse order.

Replacement of the Electronic Control Unit (ECU)

Remove the glass panel as described on page 6 of the user's instruction section.

Remove the Loose shapes.

Repeat the process above (replacement of the burner assembly).

Undo the M3 nut retaining the ECU unit and remove.

Unplug the connections from the ECU board.

Re-assemble in reverse order.

P11 MAINTENANCE INSTRUCTIONS

Replacement Handset

Follow the guide stipulated on page 6 of the users instructions “Changing the handset batteries” to load the batteries into the new handset.

Re-Pairing the handset or ECU unit

When replacement handset or ECU the two items will need to be re-paired using the following procedure.

Start the pairing process with the power to the appliance turned off.

Make sure that the remote handset has batteries installed then turn the power on to the appliance on.

Within 30 seconds of power on, press any button on the remote handset.

The LED on the handset will start to flash quickly indicating the pairing process has started. If successful pairing is achieved then the LED will show 5 slow flashes. If pairing fails there will be 3 long flashes.

If this happens then remove power to the appliance and repeat the pairing process.

Short Spares List

Component	Part No
Burner Assembly	
Injector (Mrk 400)	2108
Injector (Mrk ????)	????
ODS Unit (oxy Pilot 2900)	7280
Control Valve	6590
Electrical Control Unit (ECU)	8080
Ignition Lead	6646
Handset	8081
P11 Fuel Bed	

Your Three Years Parts Extended Warranty P11 WARRANTY DETAILS

Please read it carefully and ensure your installer has filled in the gas commissioning checklist, keep it in a safe place so that it is available when your Gas Safe engineer carries out the annual service.

This in no way reduces your statutory rights.

The warranty commences from the date of your purchase you must retain your receipt or invoice as proof of purchase.

This extended warranty specifically excludes glass and soft refractory components and any batteries.

Terms and Conditions

- 1 The appliance must be installed by a Gas Safe registered person
- 2 The appliance must be used in accordance with the users' instructions.
- 3 The appliance must be serviced annually by a Gas Safe registered person.
- 4 The service log must be correctly filled out and record of annual services must be up to date and supported by receipts in each case.
- 5 This warranty is not transferable and relates to the original installation only.
- 6 The Registration form must be correctly filled out and returned.
- 7 The appliance has not been subject to misuse or accident or been modified or repaired by any person than the authorized representative of Charlton and Jenrick Ltd.
- 8 The registration form must be returned within 1 months of purchase.

For further information please contact the Infinity help desk on 0845 5195991 or visit our web site www.CharltonandJenrick.co.uk.

Important For future reference we suggest you record the following details here and keep the receipt as proof of purchase. This information may be asked for when you contact the helpdesk. Model Paragon P11									
Serial No									
This information can be found on the label attached to the packaging and on the data badge, which is located on the appliance-----									
Retailer Name:-----									
Address :----- :----- :-----									
Date of Purchase									

Four Year Service Log Details

The following information must be completed to support by receipts as part of the conditions of the extended five-year parts warranty and the appliance must be registered by completing and return the registration document (last page of this booklet) to Infinity Fires.

Date of first service							
-----------------------	--	--	--	--	--	--	--

Engineers Name : _____

Gas Safe no								
-------------	--	--	--	--	--	--	--	--

Date of second service							
------------------------	--	--	--	--	--	--	--

Engineers Name : _____

Gas Safe no								
-------------	--	--	--	--	--	--	--	--

Date of third service							
-----------------------	--	--	--	--	--	--	--

Engineers Name : _____

Gas Safe no								
-------------	--	--	--	--	--	--	--	--

Date of fourth service							
------------------------	--	--	--	--	--	--	--

Engineers Name : _____

Gas Safe no								
-------------	--	--	--	--	--	--	--	--

GAS FIRE COMMISSIONING CHECKLIST

This Commissioning Checklist is to be completed in full by the competent person who commissioned the gas fire as a means of demonstrating compliance with the appropriate Building Regulations and then handed to the customer to keep for future reference.

Failure to install and commission according to the manufacturer's instructions and complete this Benchmark Commissioning Checklist will invalidate the warranty. This does not affect the customer's statutory rights.

Site Requirements	Yes	N/A
Was the chimney checked to ensure it only serves one flue/fire, has no obstructions and is continuous?		
Has any debris at the base of the chimney been removed?		
For brick chimney installations is there enough depth for 12 litres of debris, or precast flues 2 litres of debris? (see instructions for debris gap details)		
Have damper and register plates been removed or locked in the fully open position ensuring correct size of flue is maintained?		
If previously used for solid fuel has the chimney been thoroughly swept?		
If the chimney is pre-cast has the inside of the flue been checked for extruded cement / sealant which must be removed?		
Has the fire place been checked for under-floor air supply which must be sealed off?		
Has the chimney been inspected prior to fitting the gas fire to ensure that it is in good condition?		
Has the structure of the chimney been checked for leakage using a smoke pellet test? (See BS5440-1 for details).		
Ventilation		
Does the installation require any additional ventilation requirements as detailed in the manufacturer's instructions?		
Hearth Requirements- where fitted		
Is the hearth constructed from non -combustible material?		
Is the hearth a minimum of 12mm thick with a minimum floor to top surface of 50mm?(BS5871) or as per manufacturer's instructions?		
Is the hearth for open fronted fires a minimum of 760mm wide and has 300mm projecting from the fire opening (BS6871) or to manufacturer's instructions?		
Mounting height (where applicable) has the fire been installed to the correct mounting height- as per manufacturer's instructions?		
Firebox and Fuel Bed		
Has the fuel bed, coals, pebbles etc. been fitted to manufacturer's instructions?		
Gas Supply		
Has an isolation tap/restrictor inlet elbow been fitted for servicing?		
Has the gas supply been thoroughly purged prior to connection to remove any debris?		
Has a gas tightness test been completed prior to breaking into the gas supply and following completion of installation?(IGEM/UP/1B)		
Record burner gas pressure reading? If only the supply pressure is available a gas rate must be undertaken.(GSIUR REG26/9C)		
Record dynamic inlet gas pressure (working pressure) reading (all gas appliances running)		
Spillage test		
Installation passes smoke match test with any extractor fans turned on (see manufacturer's instructions)		
Installation		
Has the gas fire been installed and commissioned in accordance with manufacturer's instructions?		
Has the fire been installed with the correct clearance to combustible materials, as per manufacturer's instructions?		
The operation of the appliance and controls have been demonstrated to the customer including battery replacement where applicable?		
The manufacturer's literature, including Benchmark Checklist and Service record has been explained and left with the customer?		
Has the appliance been registered with the Local Authority as detailed on the Gas Safe web site and is a legal requirement and forms part of the warranty?		
Customer's Signature: (To confirm satisfactory demonstration and receipt of manufacturer's literature)	Commissioning Engineer's Signature:	

* All installations in England and Wales must be notified to be Local Authority Building Control (LABC) either directly or through a Competent Persons Scheme. A Building Regulations Compliance Certificate will then be issued to the customer.

Register Your 24 Month Warranty with Us Today

To register your appliance at www.charltonandjenrick.co.uk/warranty.

Installer Details

Name _____

Company name _____

Gas safe number _____

Date of installation _____

Your Details

Name _____

Address _____

Post Code _____

Telephone No _____

Product Details

Model : P11 Serial No _____

Date of Purchase _____

This information can be found on the label attached to the packaging and on the data badge.

Where did you purchase this product:

Name _____

Address _____

Post Code _____

Telephone No _____

Paragon P11 Packing List

P11 NG	A-0841- Glass Liners Fitted A-0842 - Black Ribbed Liners	Pre- Fix TW
P11 LPG	A-0843-Glass Liners Fitted A-0844-Black Ribbed Liners	Pre-Fix TY
Data Badge On Plate		
Burner Tray / Firebox Assembly		
Air test Completed		
Grommet (1092)		
Glass Panel		
Silicone Strip (4818)		
Liners sides / rear / top		
AAA Batteries x 2		
Remote Control Handset		
Owners Book		
Top Glass Retaining Bracket Fitted		
Glass Fixing Cover		
Nut Spinner (5435)		
Side Liner Retaining Brackets Fitted x 2		
Oxy – pilot Gap Checked		
Mains Lead Fitted		
Restrictor Plate With Label		
Top Outlet Cover		
Embaglow		
9v Transformer		
Bag of fixings		
Serial No		
Inspector		



Charlton and Jenrick Ltd

Unit D

Stafford Park 2

Telford

Shropshire

TF3 3AR