



# CE UK CA



## fireline™

### Woodtec Stove Range



### Freestanding Stove Range

5, 5 Style, 5 Wide, 5 Wide Style, 5 WD, 5WD Catalytic,  
5 Xtra Wide with 5kW Nominal Outputs.

### Installation and Operating Instructions

Please hand these instructions to the stove user when the installation is complete. Leave the stove ready for operation and instruct the user in the correct use of the appliance and operation of controls.

**Important: – These products must be installed by a suitably qualified installer.**

#### Clean Air Act Exemption

The **Woodtec 5, 5 Style, 5 Wide, 5 Wide Style, 5WD, 5WD Catalytic and 5 Xtra Wide (5kW nominal outputs)** stoves only have been exempted under the Clean Air Act 1993 to burn seasoned wood logs in designated smokeless zones in the UK. This is subject to the correct fitting of the air control plate (the part and fitting instructions are packed separately) maintaining the air wash control at a minimum opening at all times. **Instructions for wood burning MUST be followed in order to ensure compliance at all times.**



Fireline – A division of: Charlton & Jenrick Ltd  
Unit D Stafford Park 2, Telford, Shropshire, TF3 3AR  
T: 01952 200 444 F: 01952 200 480  
[www.charltonandjenrick.co.uk](http://www.charltonandjenrick.co.uk)  
A Charlton and Jenrick Group Company



**PLEASE READ ALL THESE INSTRUCTIONS CAREFULLY!**

For safety reasons it is essential that your stove is correctly installed and operated. Fireline cannot accept responsibility for any fault or consequential problems arising through incorrect installation or operation.

**TABLE OF CONTENTS**

<b>Section</b>	<b>Page No</b>
1. List of Components.....	3
2. Component Identification and Controls.....	3
3. Preparation of Stove for Installation.....	5
4. Important Safety Information	6
4.1 Warnings and important safety information.....	6
4.1.1 Instructions.....	6
4.1.2 Chimney Warning.....	6
4.1.3 Extractor Fan Warning.....	6
4.1.4 Cleaning & Chimney Sweeping.....	6
4.1.5 Fuels.....	7
4.1.6 Maintenance.....	7
4.1.7 Ventilation.....	7
4.2 Health and Safety Information.....	7
4.2.1 Handling.....	7
4.2.2 Fire Cement.....	7
4.2.3 Asbestos.....	7
4.2.4 Metal Parts.....	7
5. Installation Information.....	7
5.1 Chimney & Flue.....	7
5.2 Ventilation.....	8
5.3 Direct Outside Air Connection.....	8
5.4 Flue Draught.....	8
5.5 Connection to Chimney.....	9
5.6 Material Clearance Dimensions.....	10
5.6.1 Distances from Combustible Materials.....	10
5.6.2 Distances from Non Combustible Materials.....	10
5.7 Hearths.....	11
5.8 Accessories.....	11
5.9 Commissioning & Handover.....	11
6. Technical Data & Declaration of Performance.....	12

**Cont'd.....**

<b>7. Operating Instructions</b>	<b>13</b>
7.1 Safety Notes for your guidance	13
7.1.1 Fireguards	13
7.1.22 Modifications	13
7.1.33 Overfiring	13
7.1.44 Fume Emission	13
7.1.55 Chimney Fire	13
7.1.6 CO Alarms	13
7.2 Warnings	14
7.3 Clean Air Act (Smoke Control Zones)	14
7.4 Air controls	15
7.4.11 Single Air Control	15
7.4.22 Air Wash	15
7.4.33 Tertiary Air	15
7.4.44 Woodburning Base	16
7.4.5 De-Ashing	16
7.5 Cleaning	16
7.6 Fuels	16
7.7 Important Notes for Wood Burning	17
7.7.1 Refuelling on to a low Firebed	17
7.7.22 Fuel Overloading	17
7.7.33 Operation with Door Left Open	17
7.7.44 Primary Air Left Open	18
7.8 Lighting the stove	18
7.9 Re-fuelling	19
7.10 Shutting down	19
7.11 Shutting down for prolonged periods	19
7.12 User Maintenance	20
<b>8. Maintenance Guide</b>	<b>21</b>
8.1 Removing and Inspection Above Baffle Plate	21
8.2 Removing Firebox Liners	21
8.3 Removing Firebox Base	21
8.4 Removing Flue Spigot Collar	21
8.5 Removing Rear Casing	22
8.6 Door Hinge Adjustment	21
8.7 Smoke Control Air Limiter	22
8.8 Maintenance of Air Control	23
8.9 Adjusting Door Latch	23
8.10 External Air Kit Fitting	23
8.11 Additional Catalytic Version Servicing Information	24
<b>9. Dimensions</b>	<b>26</b>
9.1 Woodtec 5	26
9.2 Woodtec 5 Wide	27
9.3 Woodtec 5 Wide Deep (WD) and catalytic	28
9.4 Woodtec 5 Xtra Wide	29
9.5 Woodtec 5 Style	30
9.6 Woodtec 5 Wide Style	31
<b>10. Frequently Asked Questions</b>	<b>35</b>

# 1.0 List of Components

Description of Parts	Qty
Woodtec Stove Assembly	1
Operating Tool	1
Flue Spigot Collar (installed)	1
Casing Blanking Plate (packed)	1
Stove Operating Gloves	1

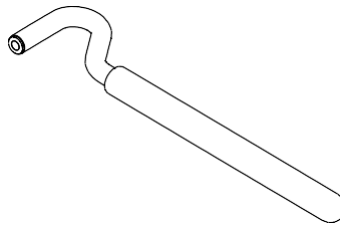
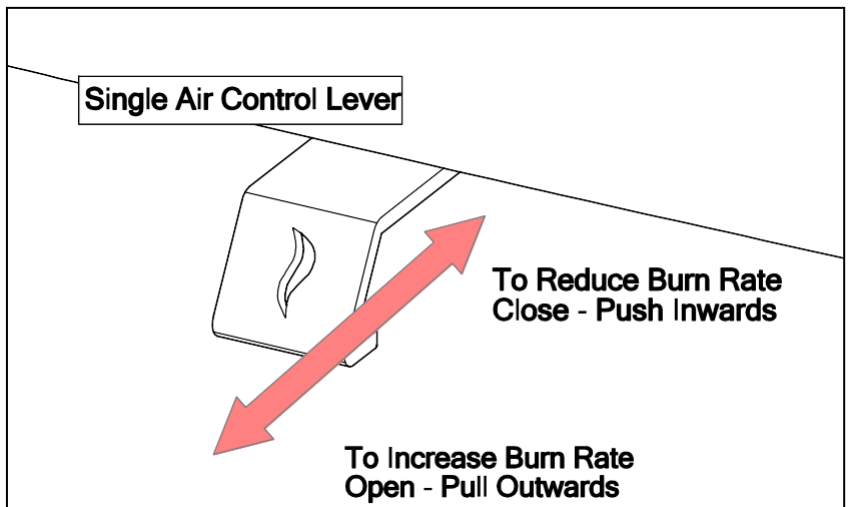
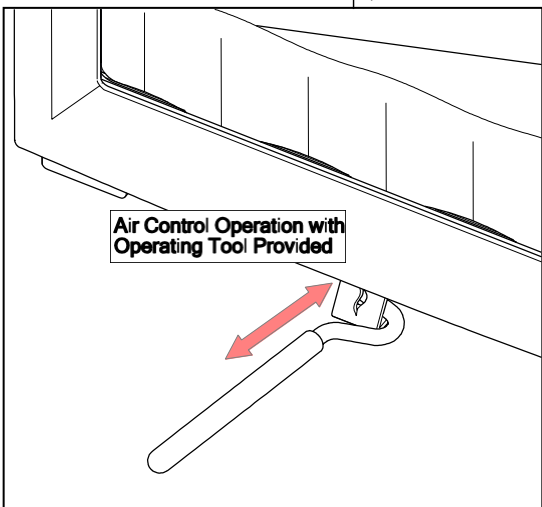
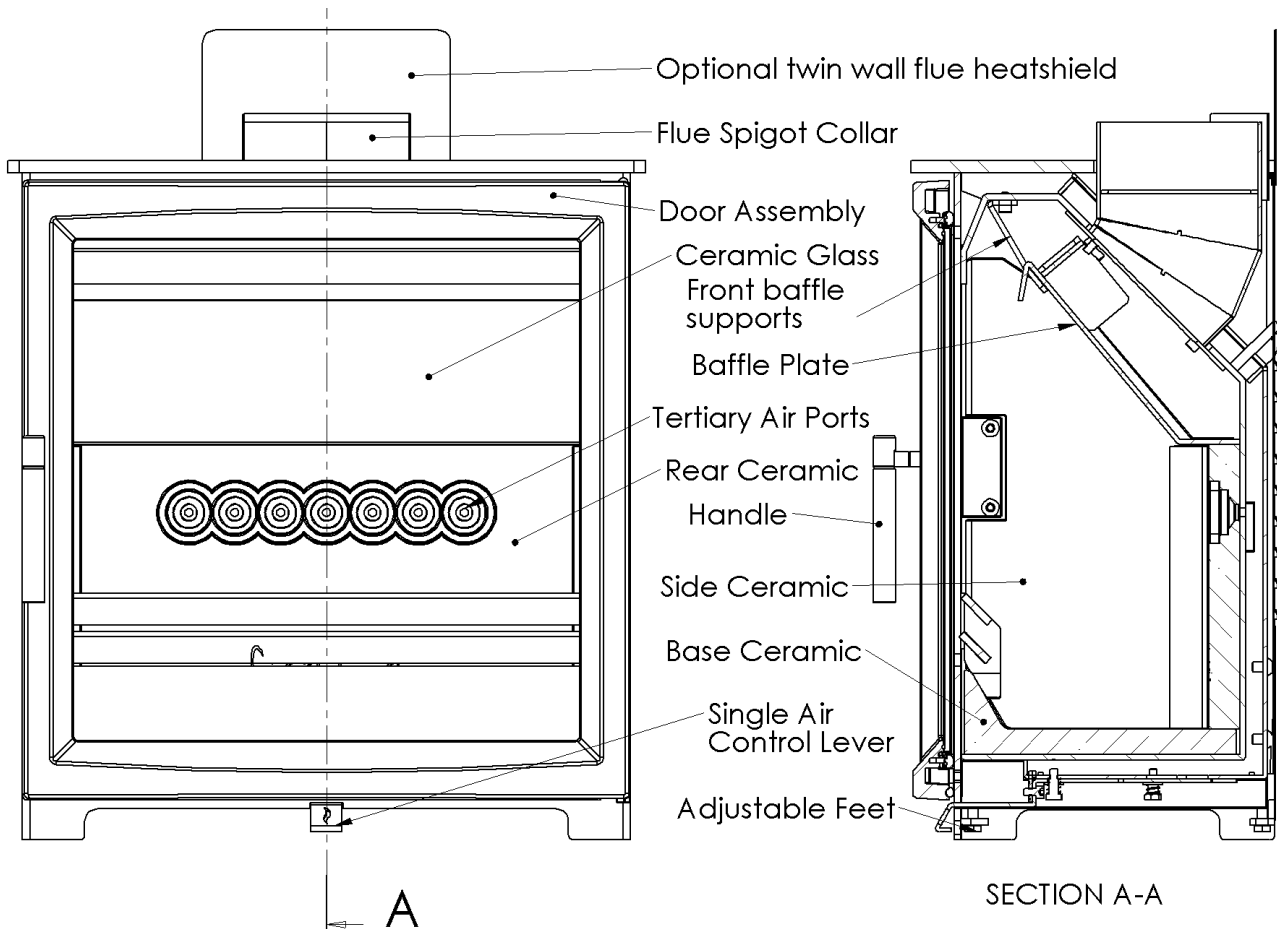

**Fig 1. Operating Tool**

May be used to operate single aircontrol lever and optional ash removal box

## 2.0 Component Identification and Controls - Woodtec Standard Models

**Fig 2**  
Woodtec Stove Assembly and Components



## 2.1 Component Identification and Controls - Woodtec Catalytic Models

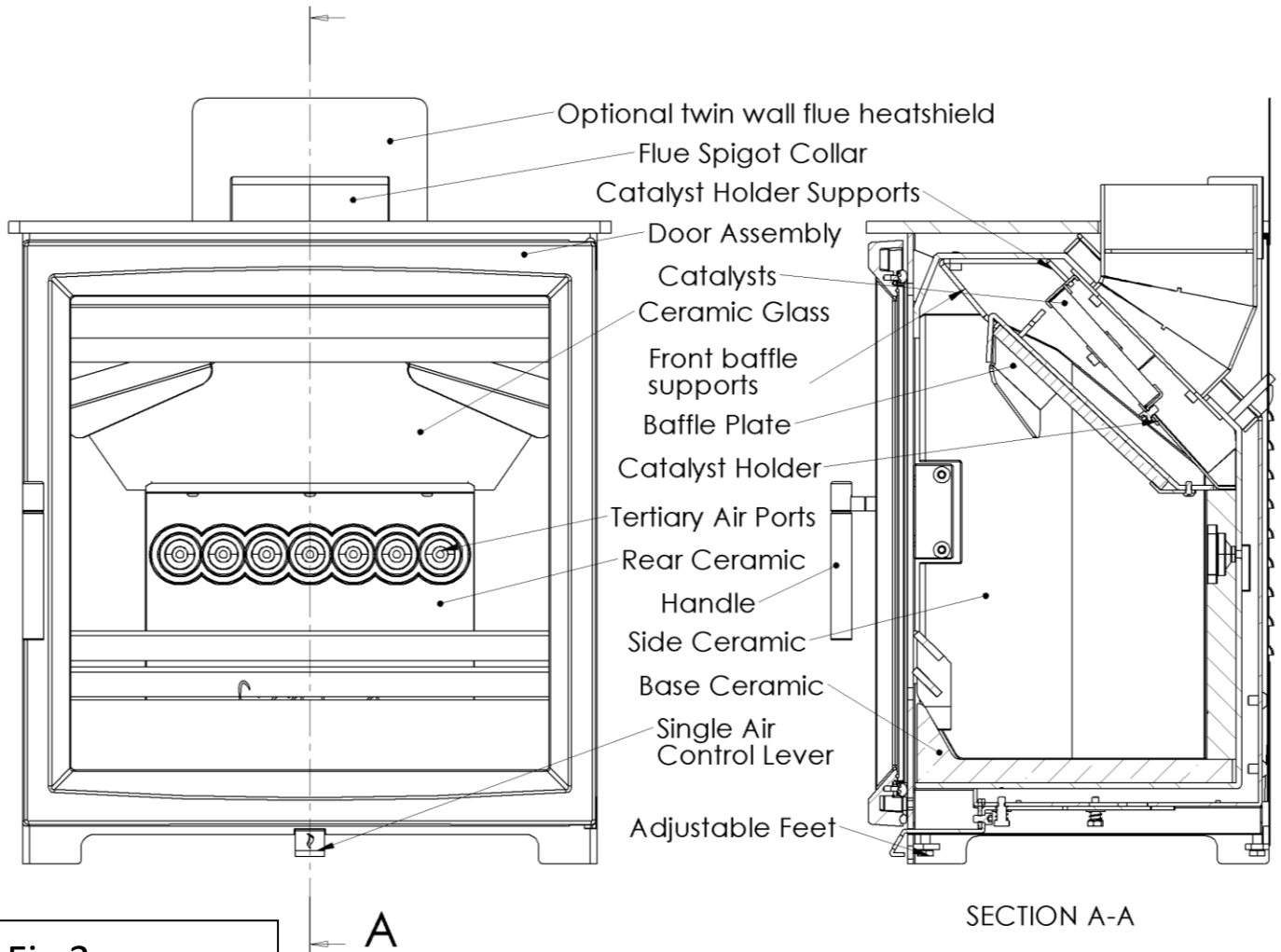

**Fig 3**  
 Woodtec 5WD  
 Catalytic Stove  
 Assembly and  
 Components

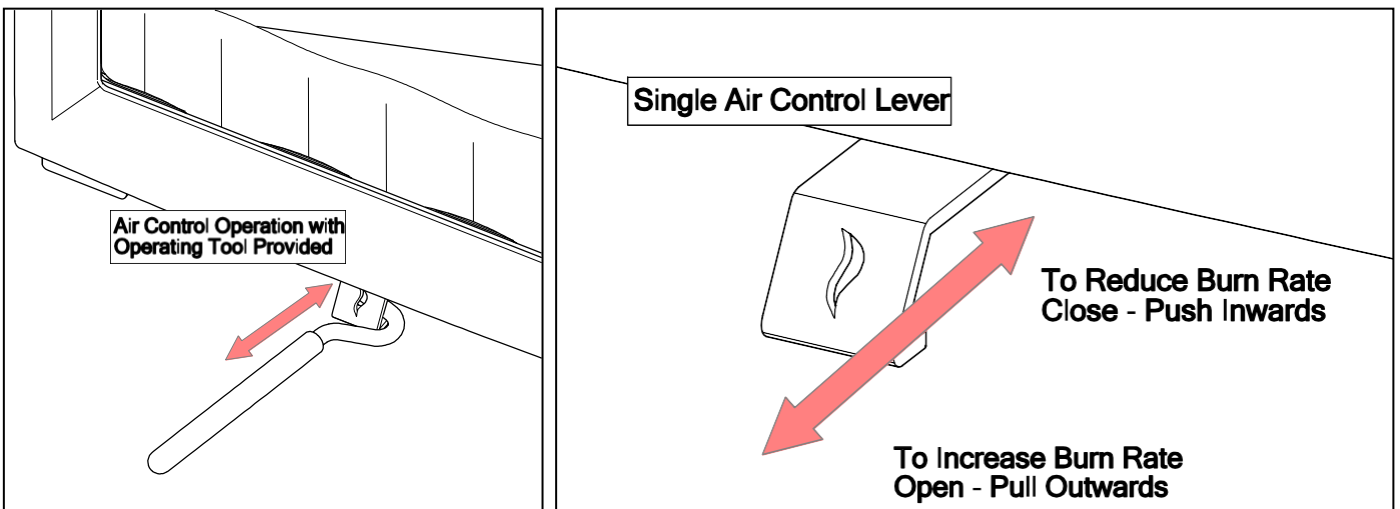

## 3.0 Preparation of Stove for Installation.

Your stove comes fully assembled, checked and packed in a protective plywood crate. Carefully cut and remove the straps and lift off the top and upper crate. Remove any plastic packaging, open the door and remove all the contents. See List of Components section (above) and check contents carefully.

### **\*\*IMPORTANT HANDLING WARNING!!\*\***

**NEVER TIP OR ROCK THE STOVE FORWARDS DURING HANDLING AS IT MAY DAMAGE THE AIR CONTROL LEVER!**

- 3.1. Remove the stove door if required for easier handling of the unit. Open the door, remove the fixing screws from the bottom hinge and lower the door downwards to disengage the upper hinge pin. When re-assembling use the same shims that were factory fitted and make sure that the door is correctly tightened in line with the stove body.
- 3.2. Remove the interior components of the stove using the following procedure. SEE ALSO MAINTENANCE GUIDE section for diagrams where required.
  - 3.2.1. Remove the baffle plate by supporting the plate with both hands and lifting the front edge upwards towards you and sliding the back edge off the back support and down slightly into the firebox. Once the rear is lowered then the front edge can also be lowered off the front baffle supports.
  - 3.2.2. For Catalytic models now remove the catalyst holder and catalysts complete. This is achieved by sliding the lower edge off the top of the rear firebox liner and lowering the assembly off the upper supports in a very similar way to removing the main baffle assembly. TAKE GREAT CARE NOT TO IMPACT AND DAMAGE THE CERAMIC CATALYST PANELS.
  - 3.2.3. Next remove the two cast ceramic firebox side liners by carefully shifting the front edges inwards towards the centre of the firebox and sliding forwards away from the 45 degree mitre joint with the back liner at the rear corners. Take great care not to chip or damage the surfaces of these ceramic components – support the rear liner so that it cannot fall over and break!
  - 3.2.4. Now remove the firebox rear liner. Handle and store these ceramic liners very carefully to one side where they will not get broken.
  - 3.2.5. Remove the firebox base ceramic from the firebox by lifting and tilting.
- 3.3. Rock the stove to the left and right side in turn and set the adjustable feet of the stove to approximately their required position. They can be re-adjusted lower later if required. **NOTE: DO NOT rock the stove forward as it may damage the air control lever!**
- 3.4. The flue spigot collar may now be configured for horizontal connection if required.
  - 3.4.1. Remove the 4 x M6 cap screws in the upper rear firebox and remove the spigot.
  - 3.4.2. Remove the rear casing by levering away from the body at the top with a screwdriver at the same time as lifting the panel upwards.
  - 3.4.3. The rear casing blanking plate can now be taken out by carefully knocking it out from the back panel by breaking the provided laser cut micro joints.
  - 3.4.4. Re-fit the back panel before re-fitting the flue spigot.

- 3.4.5. Finally the spigot may then be rotated by 180 degrees and re-fitted either using the gasket provided or re-sealing with fire cement as required.
- 3.4.6. The casing blanking plate can now be used to cover the hole in the top plate.
- 3.5. Lift the stove into its final position using an assistant to help.
- 3.6. Make the connection to the flue, chimney or liner using appropriate rigid flue pipe or adaptor, making sure to seal all joints carefully.
- 3.7. Now proceed to complete the installation of the stove according to these instructions, Building Regulations and current installation standards or HETAS advice.
- 3.8. The internal parts of the stove can be re-assembled as the reverse of the previous removal instructions before testing the stove and installation.

## **4.0 Important Safety Information**

### **4.1. WARNINGS AND IMPORTANT SAFETY INFORMATION**

#### **4.1.1. READ THESE INSTRUCTIONS CAREFULLY BEFORE INSTALLATION!**

These instructions cover the basic principles to ensure satisfactory installation of the stove, although detail may need slight modification to suit particular local site conditions. In all cases the installation must comply with current local regulations including Building Regulations, Local Authority Byelaws and other specifications or regulations including UK or EU standards referred to as they affect the installation of the stove. Approved Document J is particularly important for England and Wales and can be downloaded for no cost at:

<http://www.planningportal.gov.uk/england/professionals/en/4000000000503.html> Also of importance are Approved Documents (A.D.) L1 A and B conservation of fuel and power. The Domestic Heating Compliance Guide will also be found useful.

In addition to these instructions the requirements of BS 8303 and BS EN 15287 must be fulfilled. The installation of a stove is a notifiable building works as defined in the building regulations and it is a legal requirement under England and Wales Building Regulations that the installation is either carried out under Local Authority Building Control approval or is installed by a Competent Person registered with a Government approved Competent Persons Scheme. HETAS Ltd operate such a Scheme and a listing of their Registered Competent Persons can be found on their website at [www.hetas.co.uk](http://www.hetas.co.uk).

#### **4.1.2. Important Chimney Warning**

This stove must not be installed into a shared chimney that serves any other heating appliance.

#### **4.1.3. Extractor Fan Warning**

There must not be an extractor fan fitted in the same room as the stove as this can cause the stove to emit fumes into the room. If unavoidable the appliance must be checked with Approved Document (A.D.) 1.21 and necessary action taken.

#### **4.1.4. Cleaning and Chimney Sweeping**

**The appliance, flue & chimney must be cleaned and checked internally and externally regularly in use and especially after a period of disuse (e.g. after summer).** Lift down the baffle at least weekly to check for build up of soot or debris on the top from the flue pipe. Remove the baffle and check the flue spigot and connector is fully clear at regular intervals. The chimney and

flue connector must be swept at least annually, more often when used with sooty fuels or damp wood. The chimney or flue can usually be swept through the appliance. A wire centred sweeps brush with guide wheel is recommended. Any loose, broken or leaking joints or flue ways MUST be repaired immediately.

#### **4.1.5. Fuels**

Only use recommended fuels which are seasoned (or kiln dried) wood logs. The appliance can be damaged by burning petroleum coke, liquid fuels or general rubbish and this will invalidate your warranty and risk your personal safety. **The appliance must not be used as a rubbish incinerator.**

#### **4.1.6. Maintenance**

Annual checking and servicing of the appliance and flue by a competent engineer is recommended.

#### **4.1.7. Ventilation**

Adequate ventilation is ESSENTIAL for the safe and efficient operation of any solid fuel or wood burning appliance. Ventilation MUST be provided where required by the stove output or flue under-performance. Keep all ventilation clear and free of blockage, including the direct outside air connection where used. See VENTILATION in INSTALLATION INFORMATION section.

### **4.2. Health And Safety Precautions**

**Special care must be taken when installing this stove to meet all requirements of the Health & Safety at Work act.**

#### **4.2.1. Handling**

Adequate facilities must be available for unloading and site handling. Stoves are very heavily built so always ask for assistance when lifting and siting them. See Technical Data for weights.

#### **4.2.2. Fire Cement**

Some types of fire cement are caustic and should not be allowed to come into contact with the skin. In case of skin contact, wash immediately with plenty of water.

#### **4.2.3. Asbestos**

This stove contains no asbestos. If there is a possibility of disturbing any asbestos in the course of installation then please seek specialist guidance and use appropriate protective equipment.

#### **4.2.4. Metal Parts**

When installing or servicing this stove, proper care should be taken to avoid the possibility of personal injury. Injury may be caused by component weight, sharp parts or trapping for example and these risks should be identified and minimised.

## **5.0 Installation Information**

### **5.1. Chimney/flue**

The chimney height and the position of the chimney terminal should conform to Building Regulations. **Minimum chimney height is 4.5m and the recommended minimum diameter is 150mm wherever possible for safety margin and performance.** The chimney must be swept before connection to the stove. Check that the chimney is in good condition, dry and free from cracks and obstructions. The diameter of the flue should not be less than 125mm (spigot diameter) at any point and not greater than 200mm. If any of these requirements are not met, the chimney should be lined by a suitable method. When using a liner a 6" diameter is strongly



recommended where it can be used but failing that a 5" flexible flue liner is permitted be used for these stoves providing that the users only burn seasoned wood logs with the air limiter fitted in in full accordance with the wood burning instructions.

Where the chimney is believed to have previously served an open fire installation, it is possible that the higher flue gas temperature from the stove may loosen deposits that were previously firmly adhered, with the consequent risk of flue blockage. It is therefore recommended that the chimney be swept a second time within a month of regular use after installation.

If you have any doubts about the suitability of your chimney, consult your local dealer/stockist or chimney specialist. If there is no existing chimney then either a solid fuel compatible prefabricated block chimney or a twin-walled insulated stainless steel flue to BS 4543 can be used. These chimneys must be fitted in accordance with the manufacturer's instructions and Building Regulations.

### 5.2. Ventilation

Document J of the Building Regulations states that purpose provided ventilation is not required in England and Wales unless the appliance nominal rated output is greater than 5kW. Over 5kW 5.5 cm<sup>2</sup> of ventilation (550mm<sup>2</sup>) is required for every kW output above 5. For example 6.5 kW requires 8.25 cm<sup>2</sup> and 8 kW needs 16.5cm<sup>2</sup>. In any case, if difficulty in starting the fire or any excessive fuming is experienced, ventilation must be put in place as required to eliminate these flue problems. If a flue draught stabiliser is fitted then extra ventilation is required. See Document J of the Building Regulations for detailed guidance especially in new build properties. A specifically designed direct outside air connection may be used with these stoves to provide appropriate levels of ventilation (significantly in excess of the above requirements) directly to the stove and chimney as follows. NOTE: in order to register the installation with HETAS as of early 2016 certain extra evaluation and checking is required if using an outside air connection. If the direct air kit is used and no ADJ vent is installed then a direct registration with Building Control may also be possible.

### 5.3. Direct Outside Air Connection

These stoves are supplied with the facility of using a dedicated 100mm diameter direct connection duct through a suitable route to the outside air. It can be connected to the rear of the stove and should be fitted at the time of stove installation. Only the approved kit for these stoves should be used. This is designed to supply all the necessary air for safe combustion and operation of the stove – ***providing there is no depressurisation of the property by mechanical or other types of ventilation, the flue, chimney and ventilation duct are working correctly, and properly maintained clear of obstructions or leaks etc.*** The kit supplies all the primary, secondary and tertiary air to the stove and also provides room ventilation in excess of the Document J Building Regulations during re-fuelling via the air connection unit under the stove and so subject to no depressurisation (as above) may be used where mechanical ventilation and heat recovery (MVHR) units are used. Some additional instructions for installation are provided with the dedicated kit supplied. NOTE: in order to register the installation with HETAS as of 2016 certain extra evaluation and checking is required if using an outside air connection. If the direct air kit is used and no ADJ ventis installed then a direct registration with Building Control may also be possible.

### 5.4. Flue Draught

A draught test point is provided on the rear of the stove. Remove the grub screw and connect a draught gauge to the spigot tube. Typically, a flue draught of 2.2mm to a maximum 3.5mm

water gauge (22 to 35 Pascals) is required for satisfactory appliance performance. This relates to 12-25 Pascals at the tapping on EN13240/13229 test rigs. The flue draught should be checked under fire at high output and, if it exceeds the recommended

maximum, a draught stabiliser should be fitted so that the rate of burning can be controlled to prevent over-firing. RESEAL TEST POINT WITH GRUB SCREW AFTER USE.

### 5.5. Connection to the Chimney

This appliance is **not** suitable for use in a shared flue.

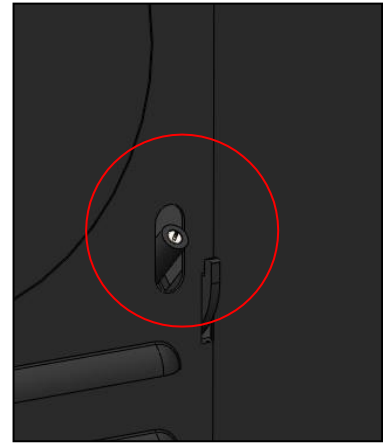

Whilst 150mm diameter flue or liner is recommended wherever possible, a suitable 5" flexible flue liner is permitted to be used on these stoves providing that they only burn seasoned wood logs with the air limiter fitted in in full accordance with the wood burning instructions.

An existing fireplace opening can be bricked up or sealed with a register plate. A short length of suitable quality rigid flue pipe of a minimum 125mm internal diameter may then be used to connect the stove to the chimney. A maximum of 150mm horizontal flue pipe can be used. This flue pipe should conform to Building Regulations. If the connecting pipe enters the vertical flue way at any other angle except vertically, ensure that the pipe end is no closer (along the direction of the pipe) than 76mm to the side or rear chimney walls. Ideally, the old fireplace should be filled in so that there is a smooth streamlined entry into the flue way. It is essential that all connections between the stove and chimney-flue are sealed and made airtight with sealing rope, clamping rings and/or fire cement or heat resisting cement where required.

Both the chimney and flue pipe must be accessible for cleaning and if ANY parts of the chimney cannot be reached through the stove (with baffle removed), a soot door must be fitted in a suitable position to enable this to be done.

## 5.6. Material Clearance Dimensions

### 5.6.1. Safety Distances from Combustible Surfaces:

Model	Side (Full wall) Twin Wall Flue	Side (Full wall) Single Wall Flue	*Rear Single Wall Flue (no shield)	*Rear Single Wall Flue (with shield)	*Rear Twin Wall Flue (no shield)	*Rear Twin Wall Flue (with shield)
<b>Woodtec 5kW inc Style</b>	400mm (From Top Plate)	450mm (From Top Plate)	300mm (From Top Plate)	100mm (From Heat Shield)	150mm (from top plate)	75mm (From Heatshield)
<b>Woodtec 5kW Wide inc Style</b>	550mm (From Top Plate)	550mm (From Top Plate)	300mm (From Top Plate)	125mm (From Heat Shield)	175mm (from top plate)	75mm (From Heatshield)
<b>Woodtec 5kW WD inc Catalytic</b>	400mm (From Top Plate)	450mm (From Top Plate)	300mm (From Top Plate)	200mm (From Heat Shield)	150mm (from top plate)	100mm (From Heatshield)
<b>Woodtec 5kW Xtra Wide</b>	500mm (From Top Plate)	500mm (From Top Plate)	250mm (From Top Plate)	150mm (From Heat Shield)	200mm (from top plate)	100mm (From Heatshield)

**\* To use the minimum clearances from a combustible back wall, the optional heatshield (supplied with the stove) MUST be fitted and twin wall flue MUST be fitted from the top of the stove. You must also continue to comply with Building Regulations combustible material distances from flue pipes unless appropriate heat shielding is used or other information is available from the flue pipe manufacturer.**

In addition it is strongly recommended that any furniture or other combustible materials are kept at least 900mm clear from the front of the stove.

NOTE: Combustible surfaces can be protected from radiant heat from the stove by adding non-combustible heat shielding between the stove and the materials with an air gap behind it. By doing so, safe distances may be substantially reduced in practice.

### **COMBUSTIBLE SHELVES AND BEAMS**

Due to the fact that combustible shelves, timber fireplaces and beams have potentially thousands of possible configurations in conjunction with stoves outset or inserted partially or fully into chambers, it is not possible to give firm guidance on dimensions to these features. As a guideline, materials that are in 'line of sight' to the stove are more likely to overheat due to direct radiation from the stove body than materials that are not in 'line of sight' (e.g. with stove fully inside a chamber). Materials above the stove are far more likely to overheat than materials alongside or below. A guideline limiting temperature for solid timber (not surface finishes) is approximately 80-85 degrees C with a normal ambient room temperature. Temperatures of combustible materials can be substantially lowered with a simple heat shield constructed of a non-combustible material and small air gap (6-12mm for example) between the shield and combustible material.

### 5.6.2. Distances from NON-combustible materials:

The stove can be recessed in a suitable sized non-combustible fireplace but a permanent free air gap of at least 50mm must be left around the sides and top and at least 50mm at the back of the stove to obtain reasonable heat output and for access to the stove for removal and maintenance. A

clearance of 150mm will give a better heat output

In accordance with Building regulations all non-combustible walls closer than 400mm to the stove should be at least 75mm thick. For practical reasons the back wall of the fireplace recess and the hearth should be made of non-combustible material.

### **5.7. Hearths:**

These stoves do not require a constructional hearth beneath them as they do not cause the floor temperature to exceed 100 degrees C. Hearths must be generally level. In all instances a non-combustible superimposed hearth extending fully underneath the stove and forming an apron of at least 225mm at the front of the stove and 150mm on either side must be provided. The superimposed hearth must not be less than 12mm thick and must have a clearly defined edge (change of level) to discourage placing of any combustible materials on or partially over it.

The appliance shall be installed on a floor with adequate load-bearing capacity. If the existing construction does not meet this requirement, suitable measures (e.g. load distributing plate) should be provided to achieve it.

### **5.8. Accessories**

Woodtec stoves are provided with a selection of accessories including stands, log store stands, and a dedicated outside air kit. Only use genuine Woodtec accessories.

### **5.9. Commissioning and Handover**

CO Alarm: Building Regulations require that whenever a new or replacement fixed solid fuel or wood/biomass appliance is installed in a dwelling a carbon monoxide alarm must be fitted in the same room as the appliance. Further guidance is available in BS EN50292:2002 and from the alarm manufacturer's instructions. Provision of an alarm must not be considered a substitute for either installing the appliance correctly or ensuring regular servicing and maintenance of the appliance and chimney system.

Upon completion of the installation, allow a suitable period of time for any fire cement and mortar to dry out. A small fire may then be lit and checked to ensure the smoke and fumes are taken from the stove up the chimney and emitted safely to atmosphere.

Advise the customer not to run the stove at full output for at 3 – 4 days. Explain that the stove can provide much more or less output than their rated heat outputs depending upon fuels, fuel loads used and how they are operated.

**Warn the customer that using excessive air (having the air controls open too wide for too long) and/or excessive fuel loads can over-fire and irreparably damage the stove. Damage caused by over firing is NOT covered by any warranty.**

On completion of the installation and commissioning, check all parts of the appliance are correctly fitted and ensure that the operating instructions and operating tools (including gloves) for the stove are left with the customer. You must be sure to advise the customer on the correct use of the appliance with the fuels likely to be used on the stove and warn them to use only the recommended fuels for the stove.

Advise the user on what to do should smoke or fumes be emitted into the room from the stove – see **Safety Notes** section. The user should be warned that they **MUST** use a suitable fireguard in the presence of children, aged and/or infirm persons.

## 6.0 Technical Data & Declaration of Performance and Conformity DoP & DoC

Ecodesign for Energy-Related Products Regulations 2010 UK SI 2010 No 2617 and EU 2015/1188 implementing 2009/125/EC

**Manufacturer:** Fireline UK, a Division of Charlton & Jenrick Ltd.

**Range Designation:** Woodtec freestanding stoves.

**Models:** Woodtec 5kW, 5kW Style, 5kW Wide, 5kW Wide Style 5kW WD, 5kW WD Catalytic, 5kW Xtra Wide nominal outputs of 5kW.

**Intended Use:** Domestic heating appliances

**Independently Performance & Safety tested by:** Kiwa Gastec, NB No: 0558, Kiwa Cermet Italia, NB No: 0476

**Constasy of Performance System:** ISO9001

Model	Woodtec 5kW inc 5 Style	Woodtec 5kW Wide inc 5W Style	Woodtec 5WD	Woodtec 5WD Catalytic	Woodtec 5kW Xtra Wide	Notes
<b>Appliance weight (packed/unpacked) (Kg):</b>	75/66	89/78	101/89	105/93	96/85	
<b>Approximate Output Range: (kW)</b>	3.5 -6.9	3.8 -7.0	4.1-7.0	4.1-7.0	3.7 - 8.0	
<b>Harmonised EN European Standard (hEN):</b>	EN13240: 2001 Amd 2: 2004	EN13240: 2001 Amd 2: 2004	EN13240: 2001 Amd 2: 2004	EN13240: 2001 Amd 2: 2004	EN13240: 2001 Amd 2: 2004	
<b>Additional Characteristics Test Standard:</b>	DIN +	DIN +	DIN +	DIN +	DIN +	
<b>Additional Particulate Emission Test Standard:</b>	PD6434	PD6434	PD6434	PD6434	PD6434	
Performance Characteristics Using Wood Fuel						
<b>Test Report Issue Date:</b>	04/17	04/17	04/19	01/22	04/17	
<b>Total Efficiency: (%)</b>	81.1	80.2	80.5	82.1	81.2	
<b>Declared nominal output: (kW)</b>	5.0	5.0	5.0	5.0	5.0	
<b>Tested nominal Output: (kW)</b>	5.0	5.1	5.0	5.1	5.0	
<b>Tested wood re-fuelling interval: (h)</b>	0.8	0.76	0.81	0.83	0.79	
<b>Flue gas mass flow: (g/s)</b>	3.9	4.3	4.1	4.2	4.1	
<b>Mean CO emission (@13% O<sub>2</sub>) : (%) (Nmg/m<sup>3</sup>)</b>	0.08(1000)	0.1(1250)	0.07(875)	0.02 (250)	0.1(1250)	
<b>Mean C<sub>n</sub>H<sub>m</sub> emission (@13% O<sub>2</sub>): (Nmg/m<sup>3</sup>)</b>	50	63	65	46	73	
<b>Mean NO<sub>x</sub> emission (@13% O<sub>2</sub>): (Nmg/m<sup>3</sup>)</b>	86	94	117	97	87	
<b>DIN+ particulates (@13% O<sub>2</sub>): (Nmg/m<sup>3</sup>)</b>	13	24	18	9	25	
<b>PD6434 Particulate Emissions High output: (gh<sup>-1</sup>)</b>	1.9	1.7	1.6	1.6	2.6	
<b>PD6434 Particulate Emissions Low output: (gh<sup>-1</sup>)</b>	1.8	1.2	1.4	1.4	1.6	
<b>Optical Density Time &gt; 0.2 High (Mins)</b>	0.5	0.2	0.0	0.0	0.4	
<b>Optical Density Time &gt; 0.2 Low (Mins)</b>	0.3	0.4	1.0	1.0	1.4	
<b>*Mean Flue Temperature: (Deg C)</b>	272	270	267	245	254	
<b>Approximate Max Log Length: (mm)</b>	300	400	400	400	450	
<b>clearSkies Level</b>	5	5	5	5	5	
<b>EEl</b>	A+	A+	A+	A+	A+	
Clearances from Combustible Materials						
<b>Side Wall: (mm)</b>	400/450	550	400/450	400/450	500	
<b>Rear Wall: (mm)</b>	300/150/ 100/75	300/175/ 125/75	200/150/ 150/100	200/150/ 150/100	250/200/ 150/100	

Signed:



Peter Mintoft  
Director  
Jan 2022

Note: This document also forms the Declaration of Conformity (DoC) for The Ecodesign for Energy-Related Products Regulations 2010 (2010 No 2617)

**NOTE:** Refuelling intervals for testing are chosen according to the standards concerned for performance testing and are comparative only. They **do not** relate directly to re-fuelling intervals that can be achieved on an installed product. Re-fuelling intervals of 0.75-1.5h for wood fuels would be usual.

## 7.0 Operating Instructions

### 7.1. Safety Notes for your guidance

**7.1.1. FIRES CAN BE DANGEROUS** – Always use a fireguard to BS 8423:2002 Fireguards for use with solid fuel appliances in the presence of children, the elderly or the infirm.

**7.1.2. DO NOT perform modifications to the appliance as this could seriously compromise safety in operation.**

**7.1.3. DO NOT OVERFIRE** – it is possible to fire the stove beyond its design capacity, this could damage the stove, so watch for signs of over firing – if any part of the stove starts to glow red, including baffle plate or fuel retainer, the fire is in an over fire situation and the controls should be adjusted accordingly. Never leave the stove unattended for long periods without first adjusting the controls to a reduced and safe setting – **careful air supply control should be exercised at all times.**

#### **7.1.4. WARNING – FUME EMISSION**

Properly installed and operated, this appliance will not emit fumes. Occasional fumes from de-ashing and refuelling may occur which is not normally of serious concern. **However, persistent fume emission is potentially dangerous and must not be tolerated.**

If fume emission does persist, then the following immediate action should be taken: -

1. Open doors and windows to ventilate room
2. Let the fire out, or remove and safely dispose of fuel from the appliance.
3. Check for flue chimney blockage and clean if required.
4. Do not attempt to re-light the fire until the cause has been identified and corrected.

If necessary, seek professional advice from chimney or stove specialists.

**Important!** – Do not fit an extractor fan in the same room as this appliance.

#### **7.1.5. IN THE EVENT OF A CHIMNEY FIRE**

- Raise the alarm to let others in the house know.
- Call the Fire Service
- Reduce the appliance burning rate by closing all air controls fully.
- Move furniture and rugs away from the fireplace and remove any nearby ornaments.
- Place a fireguard or spark guard in front of the stove.
- Feel the chimney breast for sign of excessive heat.
- Do not relight the fire until the chimney and flue ways have been examined by a professional.

If the wall is becoming hot, move the furniture away. Ensure that the Fire Service can gain access to your roof space in order to check this area for signs of fire spread.

#### **7.1.6. CO ALARMS**

Your installer should have fitted a CO alarm in the same room as the appliance. If the alarm sounds unexpectedly, follow the instructions given under “Warning Note” below.

WARNING If the CO Alarm sounds unexpectedly:-

1. Open Doors and windows to ventilate the room and then leave the premises.
2. Let the fire go out.

## 7.2 Warnings:

This appliance is **not** designed for open operation and therefore should **not** be operated with the doors open.

This stove is designed to burn wood cleanly with high efficiency. However, for this product to work properly it must be used correctly. If used correctly this stove will burn with the very useful feature of clean glass.

It is **essential** that the stove has an adequate air supply for combustion and ventilation. DO NOT block any ventilators provided. The primary, secondary and tertiary air inlets must be kept clear of obstruction.

**Warning!** This appliance will be very **hot** when in operation and due care should be taken when operating the controls. A tool and pair of quality leather gloves are provided to assist safe operation.

Do not use an aerosol spray on or near the stove when it is alight.

## 7.3 The Clean Air Act 1993 and Smoke Control Areas

Under the Clean Air Act local authorities may declare the whole or part of the district of the authority to be a smoke control area. It is an offence to emit smoke from a chimney of a building, from a furnace or from any fixed boiler if located in a designated smoke control area. It is also an offence to acquire an "unauthorised fuel" for use within a smoke control area unless it is used in an "exempt" appliance ("exempted" from the controls which generally apply in the smoke control area).

In England appliances are exempted by publication on a list by the Secretary of State in accordance with changes made to sections 20 and 21 of the Clean Air Act 1993 by section 15 of the Deregulation Act 2015. Similarly, in Scotland appliances are exempted by publication on a list by Scottish Ministers under section 50 of the Regulatory Reform (Scotland) Act 2014. In Northern Ireland appliances are exempted by publication on a list by the Department of Agriculture, Environment and Rural Affairs under Section 16 of the Environmental Better regulation Act (Northern Ireland) 2016. In Wales these are authorised by regulations made by Welsh Ministers.

The Fireline Woodtec 5, 5 Wide and 5 Xtra Wide (5kW nominal outputs) stoves have been recommended as suitable for use in smoke control areas when burning wood logs. This is conditional upon fitting the supplied secondary air control limiters and following the wood burning instructions precisely.

Further information on the requirements of the Clean Air Act can be found here: <https://www.gov.uk/smoke-control-area-rules> . Your local authority is responsible for implementing the Clean Air Act 1993 including designation and supervision of smoke control areas and you can contact them for details of Clean Air Act requirements.

## 7.4 Air Controls

**Keep air controls and inlets/outlets clean and free from ash or debris at all times. Keep direct outside air inlet grille (if fitted) clean and clear at all times.**

**Do not leave air control fully open unless monitoring the fire as over firing damage can result which is not covered by any warranty.**

### 7.4.1 Single Air Control Operation

Secondary (air wash) and tertiary air is automatically controlled by the single control lever at the bottom, underneath the stove door. The stove does not require Primary air as it only burns wood. The fully IN position is the OFF position and closes off combustion air to the firebox. The off position should only be used if absolutely necessary for very slow burning and will cause the glass to become blackened, the chimney to gradually become tarred and smoke to be emitted from the stove.

**Wood burning:** Pull the air control lever fully OUT for maximum air to start or revive a wood fire. Returning the lever towards the centre position will reduce the air supply progressively to reduce the burn rate. The nominal burn rate is usually achieved when the stove is fully warmed up (2-3 loads of logs) and burning 2 dry hardwood logs by having the lever very approximately 30-35mm pushed IN from the fully out (maximum) position. This is only a rough guide as flue and fuel conditions will vary the required position. The fire will automatically be supplied with the correct mix of secondary and tertiary air for complete combustion. The maximum position conveniently provides a boost of primary air as well to get new fuel burning quickly in order to minimise smoke. Do not leave on maximum setting unless monitoring the fire to ensure over firing damage does not occur.

### 7.4.2 Air Wash

All Fireline stoves are provided with a sophisticated “air wash” system to assist in keeping the fire as visible as possible and reducing cleaning intervals. This secondary air supply to the stove is controlled through the main single air control. The Clean Air Act air restrictor will deliberately prevent full closure of this control on the Wood side of operation.

The glass will not remain fully clear indefinitely, entirely depending on fuel, flue and operational settings, and will require cleaning with stove glass cleaner or ceramic hob cleaner from time to time.

### 7.4.3 Tertiary Air

This appliance is also fitted with a patented tertiary air combustion system that burns otherwise uncombusted gasses in the products of combustion thereby improving efficiency, increasing heat output and decreasing unwanted atmospheric emissions. The Tertiary air supply to the stove is controlled automatically by the draught in the flue and firebox and the single air control. At certain stages of burning you will notice “jets” of swirling flame emerging near the air holes to the rear of the firebox. This is not always visible depending upon the fuels and burn cycle stage so there is nothing untoward happening if it cannot be seen.



#### 7.4.4 Wood burning base

Your stove is fitted with a ceramic wood burning base. This is designed to retain the charcoal pieces generated as the logs disintegrate and maintain ideal conditions for log combustion. If the char bed builds up to a point where it is considerably above the front ceramic edge of the base, then the stove should be operated maximum air opening (pulled fully out) for a while to burn some off. Alternatively, a portion of the char should be carefully removed into a fireproof receptacle and placed safely away from combustible materials outside the property. Fireline provide an optional stainless steel scoop box kit to assist with this and details are available from your retailer if required. NEVER retain burning char in an indoor space.

#### 7.4.5 De-Ashing

Before re-lighting the fire the base ceramic of the stove should be partially or completely cleared of the old ash and fire bed that was present. Fireline provide an optional stainless steel scoop box kit to assist, generally making this a one scoop operation. Details are available from Fireline or your retailer if required.

### 7.5 Cleaning

**Glass:** Despite the advanced air wash system provided, the glass will still need cleaning from time to time depending on the fuel quality and burning rates used. Never clean glass when the stove is hot. Always use stove glass cleaner or ceramic hob cleaner, which is available from your stove retailer or supermarket. As an alternative, use a wet cloth with some of the wood ash if burning wood but be very careful to use very clean ash so as not to scratch the glass. DO NOT use coal ash to clean the glass.

**Outer body:** The outer body simply needs to be dusted or wiped with a clean cloth from time to time. DO NOT use wet cloths as it can spread plaster, cement, fire cement or fire board dust and subsequently cause the paint to turn grey with heat where it has been wiped. DO NOT use any kind of furniture polish or cleaning agent other than your stove suppliers recommended paint.

**Inner firebox:** Brush the inside of the firebox clean from time to time to check the integrity of the plates and liners etc. See Maintenance Guide section for instructions on how to remove parts of the stove. It is not normally necessary to re-paint inside the firebox due to the high temperatures that mean that the paint does not have much effect before being burnt off. Steel and high quality cast ceramic liners are very resilient firebox materials and will give reliable service without major cleaning or work on the firebox. The ceramic liners are very durable but may require replacement occasionally depending upon fuels and the type of usage experienced. Firebox linings are not covered by warranty, as they are a wearing consumable part.

**Baffle:** It is essential to check the top of the baffle for build up of soot and ash regularly when in use and after a long period of disuse – e.g. summer. From time to time remove the baffle if necessary to ensure that the flue way entrance is clear. Lift the front edge of the baffle upwards and forwards to slide the rear edge off its support. Lower the rear edge and then slide the baffle off its front supports to leave it free for removal. See maintenance section for further details.

**Air Supply:** It is essential to check the air supply grille on the outside of the property if the direct outside air connection is installed. Regularly brush or vacuum out any debris, cobwebs or similar materials to ensure that the air supply is not restricted. Ensure the air intake chamber visible underneath the ash pit section with the stove door open is kept free of excessive ash or debris.

### 7.6 Fuels

The appliance has been tested and approved burning dry, well-seasoned logs. This is the recommended fuel. For other fuels please contact the manufacturer for advice.

**Note: Warning!- Petroleum coke fuels or household waste must not be burnt on this appliance.**

Should any difficulties arise over fuel quality or suitability, consult your local Woodsure registered log fuel merchant.

### **7.7 Important Information for Wood Burning**

With a full load of wood and burning near nominal output the stove will need to be refuelled approximately every 45 mins -1.5 hours. One or two large logs will burn longer than a number of smaller ones. Wood can usually be stacked higher in the stove than solid mineral fuel but care must be taken that logs do not touch the baffle or the glass panel. **Do not stack logs above the level of the tertiary air inlet profiling in the rear ceramic firebox liners at the back of the stove.**

Always make sure that flames are visible above the wood after re-fuelling for cleanest burning. **Burning without flames above the fuel will create unnecessary smoke. After re-fuelling open the single air control fully to the Wood (left) side for 3 minutes or until the logs are fully blackened to achieve full flames above the fuel.**

Wood burns best on a bed of ash and it is therefore only necessary to remove surplus ash from the stove occasionally.

Burn only dry, well-seasoned wood, which should have been cut, split and stacked - under cover from rain - for at least 12-24 months with free air movement around the sides of the stack to enable it to dry out. Burning wet or unseasoned wood will create tar deposits in the stove and chimney and will not produce a satisfactory heat output. **Wood that is not properly dry ('dry' is considered to be less than 20% internal moisture content) uses up energy from the burn process to evaporate the water inside the wood thus creating very poor conditions for combustion.** The main cause of burning problems with wood stoves is due to excessively damp wood. Wood can appear perfectly dry on the outside but still contain 40-50% water on the inside. A moisture meter can be purchased from stove and equipment suppliers if you wish to check your wood source is correct. Split a log and check the inside as well as the outside.

#### **7.7.1 Refuelling on to a low fire bed**

If there is insufficient burning material in the firebed to light a new fuel charge, excessive smoke emission can occur. Refuelling must be carried out onto a sufficient quantity of glowing embers and ash so that the new fuel charge will ignite in a reasonable period. If there are too few embers in the fire bed, add suitable kindling and a firelighter if necessary to prevent excessive smoke.

#### **7.7.2 Fuel overloading**

The maximum amount of fuel specified in this manual should not be exceeded, overloading can cause excess smoke. Never load fuel above the centre of the tertiary air profiling in the back ceramic firebox liner or allow them to touch the glass. All models max log diameter = approx. 150mm. Max length = 300mm for 5, 400mm for 5 Wide & 5 Wide Deep, 450mm 5 Xtra Wide models. A typical fuel load is two logs, one log is acceptable ONLY if loading onto a hot, well established fire bed.

#### **7.7.3 Operation with door left open**

Operation with the door open can cause excess smoke and spillage into the room. The appliance must not be operated with the appliance door left open.

#### 7.7.4 Primary Air left open

The single air control does not provide primary air to the fuel bed and so prevents inadvertent leaving open of primary air inlets.

#### 7.8 Lighting the Stove

We recommend that you have two or three small fires before you operate your stove to its maximum heat output. This is to allow the paint to cure steadily and to give a long service life of the paint finish. During this curing in process you may notice an unpleasant smell whilst the finishes finally cure. It is non-toxic, but for your comfort we would suggest that during this period you leave all doors and windows open.

First, open the single air control fully by pulling full OUT. Load the firebox with three or four fully dry small-medium logs in a crossed pattern.



Next add plenty of dry kindling sticks and a firelighter on top of the 4 logs. A crib lattice pattern or leaning the wood sticks against the back firebrick with plenty of air space between tends to work well.

Light the firelighter(s), leaving the air control fully open and close the door. If condensation builds up then it can help to leave the door slightly ajar for a minute or two until the glass warms slightly and condensation no longer forms. It should not be necessary to leave the door open for long but DO NOT leave the stove unattended if you find it necessary to leave the door ajar.

The kindling will burn and steadily set light to the logs by radiation and breaking down to charcoal gradually and with fewer emissions than the traditional logs on top methods. If the logs fail to light properly it could indicate that the logs need further seasoning or drying and are not as moisture free as expected.



Allow the fuel to reach a steady burn and usually the initial fuel can be left to burn down to charcoal without much further attention. DO NOT close down the air controls during the initial ignition burn. If the fire dies before the logs are properly burnt through, add further kindling or small split logs so that a bright fire can be maintained. Build the fire up as soon as the flames have died down from the ignition load carefully by adding a couple of small well split logs at a time. Do not overload the fire bed with more than two to three logs at a time.

Once you have a good fire bed established across the base, further fuel can be added step by step as required. Don't be tempted to overload the fire bed with fuel all at once or close down the air controls until the fire is really well established for some time. Once the ignition period is completed and the stove is fully hot, gradually reduce the air control opening to establish the burning intensity you require.

## **7.9 Re-fuelling**

When burning wood, the fire will die down as the fuel is consumed. When the flames disappear, and the remainder is breaking down into glowing embers it is an appropriate time to consider re-fuelling. NOTE: If the flames disappear and there are still lumps of solid wood left this indicates excessive internal moisture in the wood, too low a firebox temperature (running too cool), too small a fuel load or insufficient air supply/flue draught.

**NOTE:** To eliminate unwanted smoke emission, after loading new logs on to the fire, open the air wash control up fully for 3 minutes or until the logs are blackened all over to boost the fire and get flames issuing from the top of the fuel as soon as possible. When flames are well established, reduce the air wash to the running setting required. **Burning without flames above the fuel will create unnecessary smoke.** Do not load fuel above the centre of the tertiary air inlet hole profiling at the back of the firebox.

Loading 1 or 2 large sized logs weighing 1-2kg DRY will produce a good output with reasonable burn time. Small logs will burn up quicker producing a high output and more emissions for a short time, and a large log will take longer to burn and produce less output and less emissions over a given time. These appliances are approved for intermittent operation on wood (0.75 to 1.5 hour burn cycles) although longer burn times can be achieved by fully loading the firebox, getting the fuel burning well and then shutting the air control right down (see below). This will produce a long but smoky/tarry burn. The fire will then need reviving by first opening the air controls and then using small pieces of wood and plenty of air to get flames issuing from the wood again. Never load fuel above the rear firebox tertiary air profiling or allow it to spill onto the glass.

## **7.10 Shutting Down**

The stove will normally shut down by itself as the fuel is consumed so there is no need to close the air control towards the end of the burn. In order to shut down the stove for other reasons, close the single air control to the fully IN position. If the control is left in this position, the fire will eventually go out but it will also cause the glass to blacken and tar to be formed. If you want to revive the fire it is recommended that the air control is opened fully initially.

**Warning!** - The stove will remain **very hot** for a considerable time after the fire has died down or been extinguished.

## **7.11 Shut down for prolonged periods**

If the stove is to be left unused for a prolonged period of time then it should be given a thorough clean to remove ash and unburned fuel residues. To enable a good flow of air through

the appliance to reduce condensation and subsequent damage, leave the air controls open. It is important that the flue connection, any appliance baffles or throat plates and the chimney are swept prior to lighting up after a prolonged shutdown period.

## **7.12 User Maintenance**

See also the Cleaning section above and Maintenance Guide Section below for further information.

Inspect the inside of the firebox and above the baffle plate every week during use.

Where the chimney is believed to have previously served an open fire installation, it is possible that the higher flue gas temperature from the stove may loosen deposits that were previously firmly adhered, with the consequent risk of flue blockage. It is therefore recommended that the chimney be swept a second time within a month of regular use after installation. **See chimney cleaning section in section Warnings and Important Information.** Inspect the inside of the stove and the flue ways and ensure they are 100% clear after a period of disuse (e.g summer).

Check all rope seals for completeness, wear and that there are no gaps between the ends etc. Any gaps must be eliminated and ropes must be re-adhered to their grooves with suitable rope seal cement where required. Worn or missing rope seals will affect appliance operation, control and emissions output and can lead to overheating damage.

Check all air intakes and outlets within the stove for cleanliness and remove any ash or debris build up by suitable means.

Check outside air ventilators and stove air inlets are clean and unobstructed.

**Only use manufacturers recommended replacement parts on the appliance.**

## 8.0 Maintenance Guide

- 1.1. Removal of or Inspection above Baffle Plate.** 1. First lift upwards at the front and at the same time sliding the rear forwards off the back baffle support bracket. 2. Next lower the rear edge into the firebox and allow the front of the baffle to slide off the front baffle support brackets. 3. Finally rotate the baffle and lift out of the firebox.



- 1.2. Removing Firebox Liners** 1. First bring the front edges of the left and right firebox liners inwards at the front as you slide them forwards until they disengage from the rear liner. Unscrew and remove the baffle support brackets to assist if required. Then tilt them slightly and remove from the firebox – **NOTE: Ensure that the rear firebox liner does not fall forwards and break!** 2. Remove the rear firebox liner being very careful not to damage the profiling at the top which is delicate.

- 1.3. Removing firebox base components.** Remove the firebox liners as above. Now gently lift up and rotate the base ceramic piece slightly to lift it out through the firebox front opening.

- 1.4. Removing Flue Spigot Collar.** Unscrew 4 x M6 securing screws from inside the firebox and remove spigot collar. When re-assembling either use a suitable fireproof gasket or fire cement.

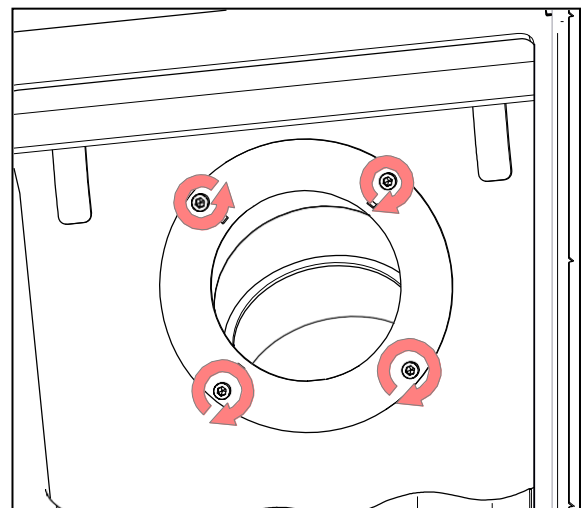

- 1.5. Removing Rear Casing.** 1. Unscrew screws securing rear casing to stove back.
2. Very carefully lever the upper edges of the casing out from under the top plate of the stove and then lift the casing up and off the rear securing hooks. The rear spigot outlet blanking plate can now be removed if required. Replacement requires springing the casing inwards and sliding down onto the retaining hooks.

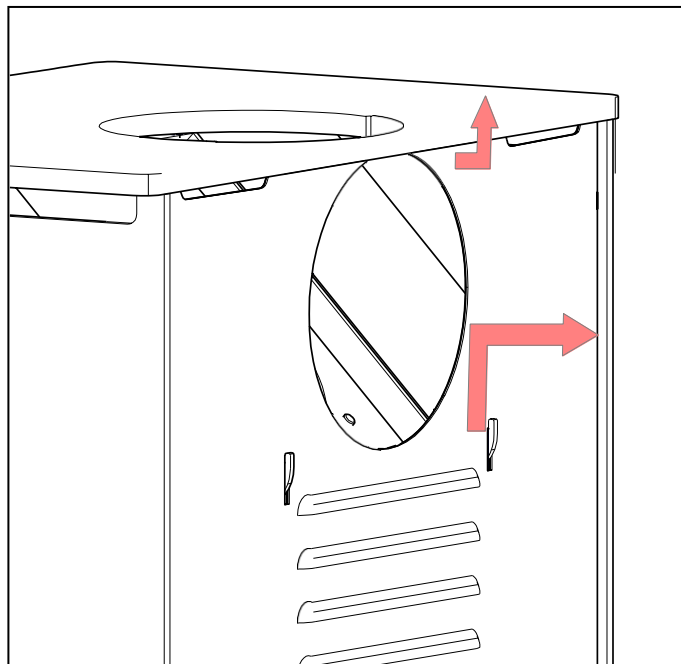

- 1.6. Door Hinge Adjustment.** Door alignment may be adjusted by opening the door then slackening the door hinge securing screws and re-positioning the hinge to suit. This will adjust the horizontal alignment. For front to back alignment shims are provided to pack the hinges to the correct position either by removing the factory fitted ones or adding more. Check the door seals with a paper strip all around after any adjustment to prove they are still sealing correctly.

- 1.7. Smoke Control Air Limiter.** If the stove is to be used to burn seasoned wood logs in a Smoke Control Zone in the UK, the Smoke Control air limiter bracket must be fitted. This bracket prevents the air control being completely closed when the stove is used to burn wood. Gently lie the stove on its side or back. Remove the air box from the base of the stove by removing the 4 x securing screws and lift away. The air limiter bracket may then be fitted to the air control slider as shown with the 1 x M6 screw provided. Check operation limits the movement to that specified on the instruction sheet accompanying the air limiter.

**Do not lean the stove forwards when moving it to access the base as it will likely damage the air control lever.**

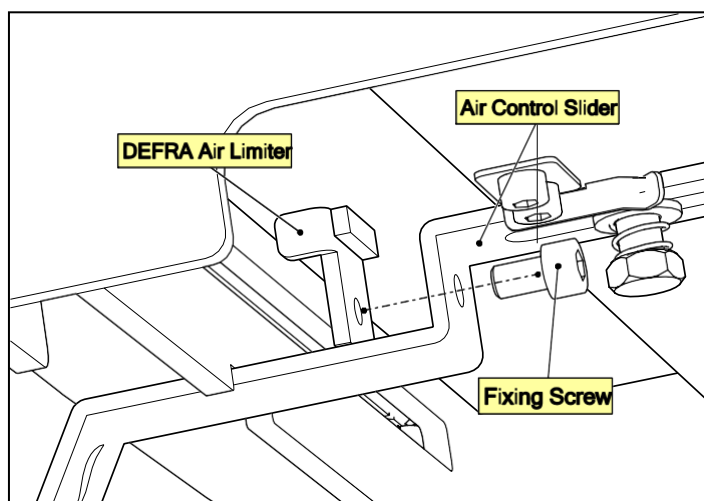
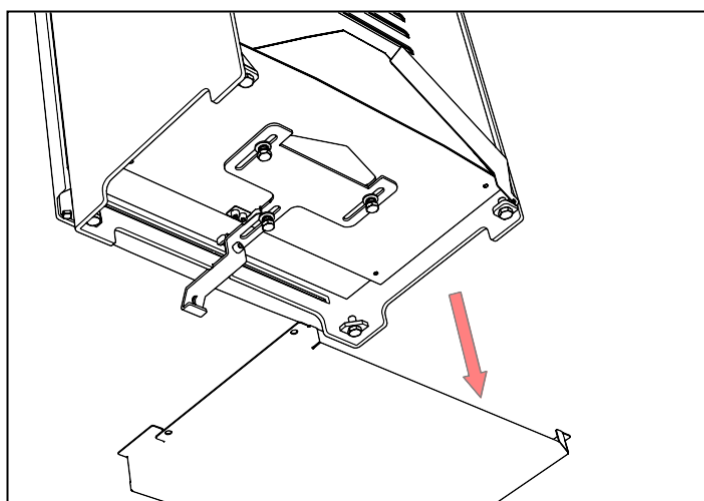

**1.8. Maintenance of air control valve.** The main air control valve is mounted underneath the air plenum chamber which is immediately beneath the firebox base. To access this for thorough cleaning firstly remove the base outside air box. Invert the firebox for access. To remove the outside air box remove 4 x fixing screws from the bottom of the firebox. Now remove locking nuts and springs from the control lever and lift the slider off. Replacement is the reverse of disassembly.

**1.9. Adjusting Door Latch.** The handle assembly may be adjusted on the door by loosening the fixing screws and sliding up or down as required. For maintenance, the internal cover over the roller latch inside the stove body can be removed from inside the firebox. NOTE: ensure that the cover is fully sealed when replacing this component because air leaks may occur if care is not taken.

**1.10. External Air Kit fitting.** Instructions come with the external air kit but as a general guide the following can be used. Firstly unpack the contents of the external air kit and locate the air box that needs to be fitted to the rear of the stove. Next remove the rear casing of the stove. Remove the cut-out at the base of the rear casing to allow it to be re-fitted once the external air box is in place. Fit the external air box to the back of the stove as shown.

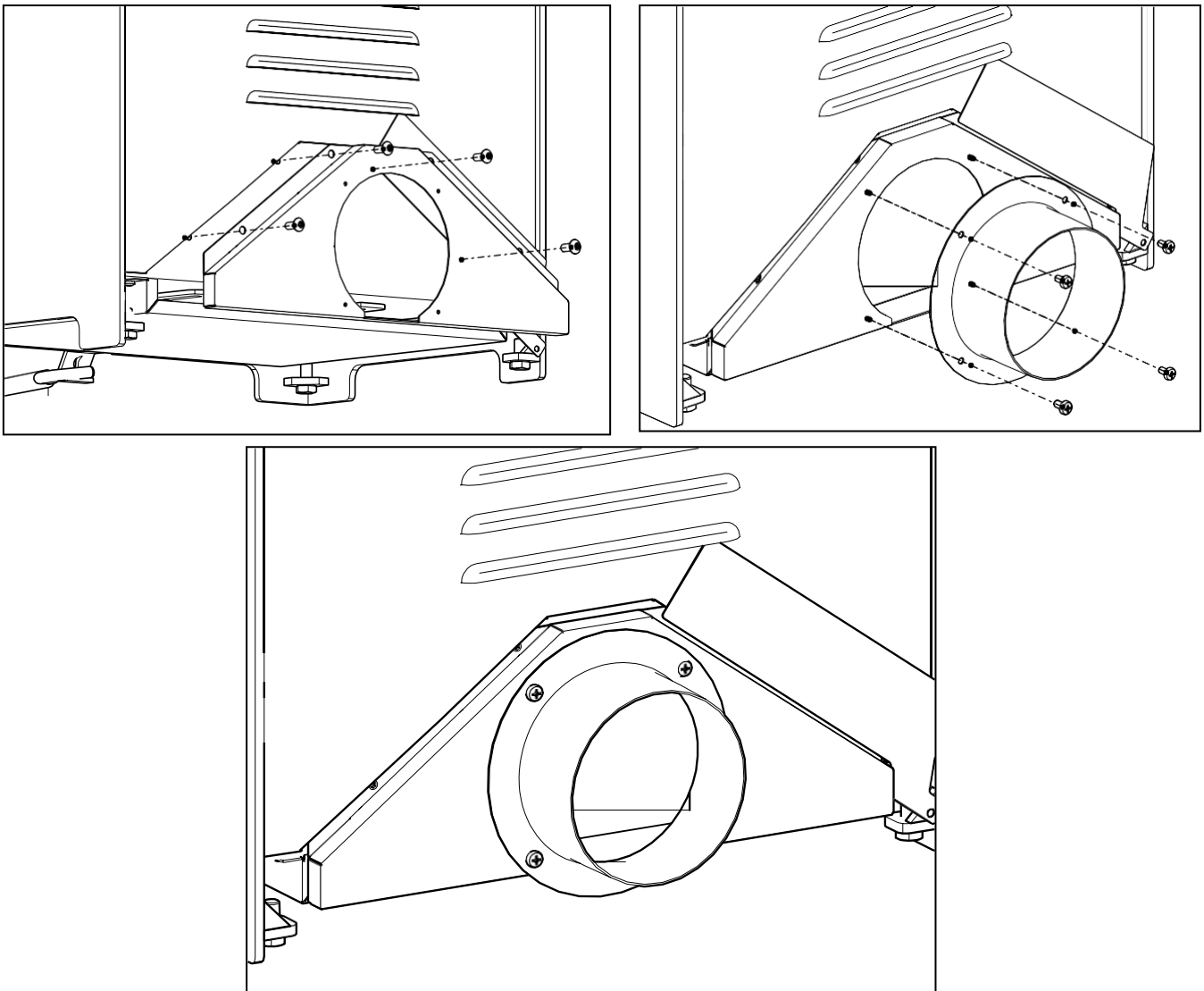



## 1.11. Additional Instructions for Woodtec 5WD Catalytic Models

### 1.11.1. Removal of or Inspection above Baffle Plate.

- 1.11.1.1. 1. First lift baffle assembly upwards at the front and at the same time sliding the rear forwards off the back baffle support bracket.
- 1.11.1.2. 2. Next lower the rear edge into the firebox and allow the front of the baffle to slide off the front baffle support brackets. Finally rotate the baffle assembly slightly and lift out of the firebox.

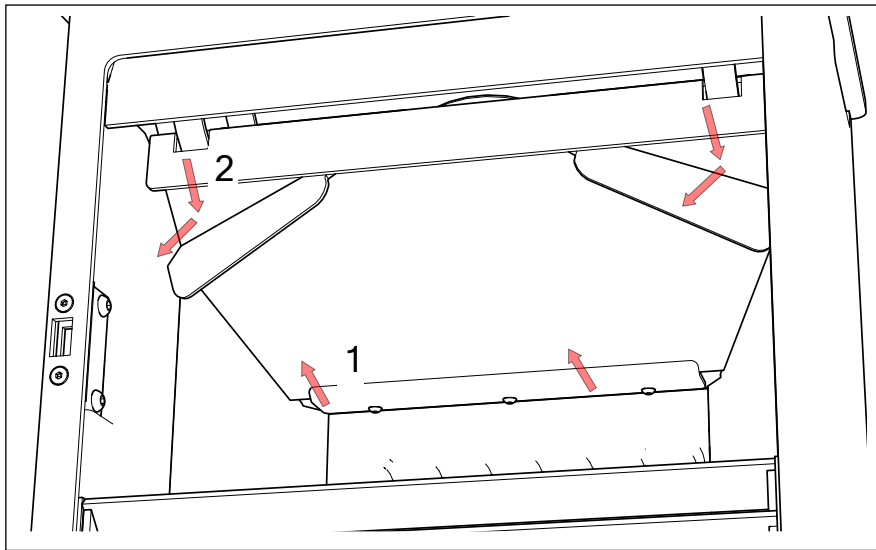

**Make sure that the bypass slots at the bottom edge of the catalyst holder - on top of the rear firebox liner - are clear of all debris and soot etc.**

### 1.11.2. Removal of Catalyst Holder Assembly Including Catalysts:

- 1.11.2.1. 1. The catalyst holder is removed in a similar way to the baffle assembly. Slide lower rear edge of the catalyst holder assembly off the rear firebox liner whilst sliding upwards slightly on the upper support brackets.

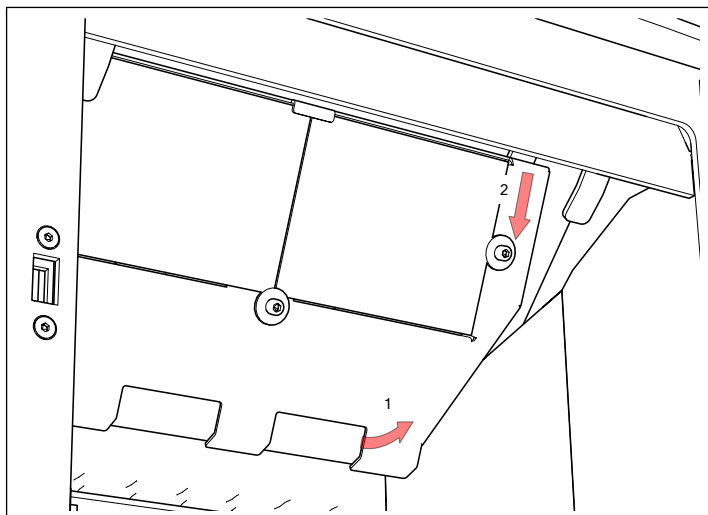

- 1.11.2.2. 2. Next lower the bottom edge into the firebox and slide the top of the catalyst holder assembly off the upper supports. Rotate the assembly slightly to remove from the firebox.

### 1.11.3. Servicing of the Catalysts

**1.11.3.1. General cleaning:** Catalysts are not “used up” by normal use but can become dusty with ash and benefit from gentle cleaning with a brush, vacuum cleaner with brush attachment fitted or and airline blow nozzle to ensure that the airspaces are fully clear in between the open cells of the ceramic foam structure. Do not clean with thinners, solvents or other materials. Stubborn tar that has been built up by slumbering the stove can usually be gently burnt off with a gas blow torch. Take care not to damage the catalyst by overheating as this can cause the noble metal coating to break down when overheated with direct flames.

**If in any doubt about the cleanliness or effectiveness of the catalyst panels, they can be replaced with genuine replacements available from Charlton & Jenrick Ltd.**

**1.11.4. Replacement:** If the catalysts are broken or damaged and replacement is necessary, they can be removed from the holder assembly very simply.

**1.11.4.1.** Remove the holder from the stove and then remove the 3 x stainless steel screws and washers that secure the catalyst panels into the holder as shown below.

**1.11.4.2.** Replace the catalyst panels using new 3mm ceramic paper gasket material wrapped around the sides of each panel. This can be cut to size from a sheet using a craft knife or household scissors or cut to length from 25mm wide roll. A single strip is also used between the two panels. Do not cover or overlap the flow surfaces of the catalysts with any gasket materials.

Very carefully ease the catalyst panels into the holder ensuring that they are not cracked or broken during the process. Use finger pressure only and do not use hard plastic or metal tools as these will damage the ceramic cell structure

**1.11.4.3.** Re-assemble the catalyst holder assembly screws and washers to secure. Re-fitting into the stove can now be completed in the reverse order to dismantling.

**1.11.4.4.** Make sure that the bypass slots seen at the bottom edge of the catalyst holder are clear of all debris and soot etc

**1.11.4.5.** Replace the baffle assembly into the stove and any other components removed.

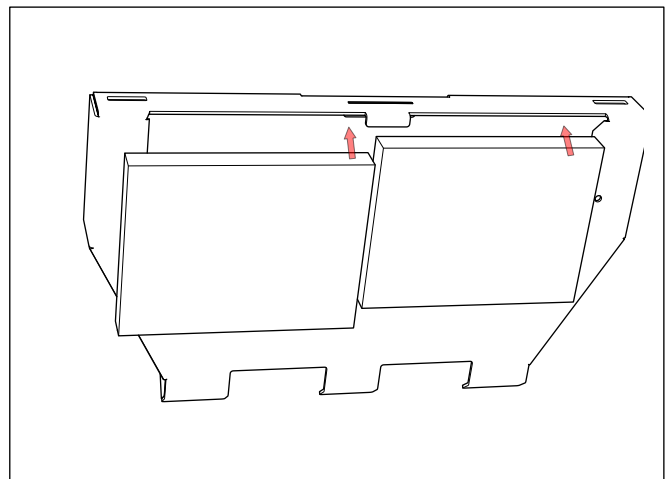
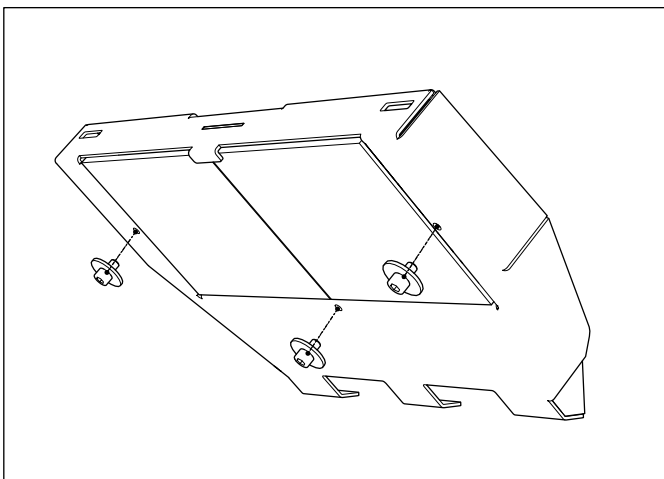

## 9.1 Woodtec 5kW Stove Principal Dimensions

All Dimensions shown in mm.

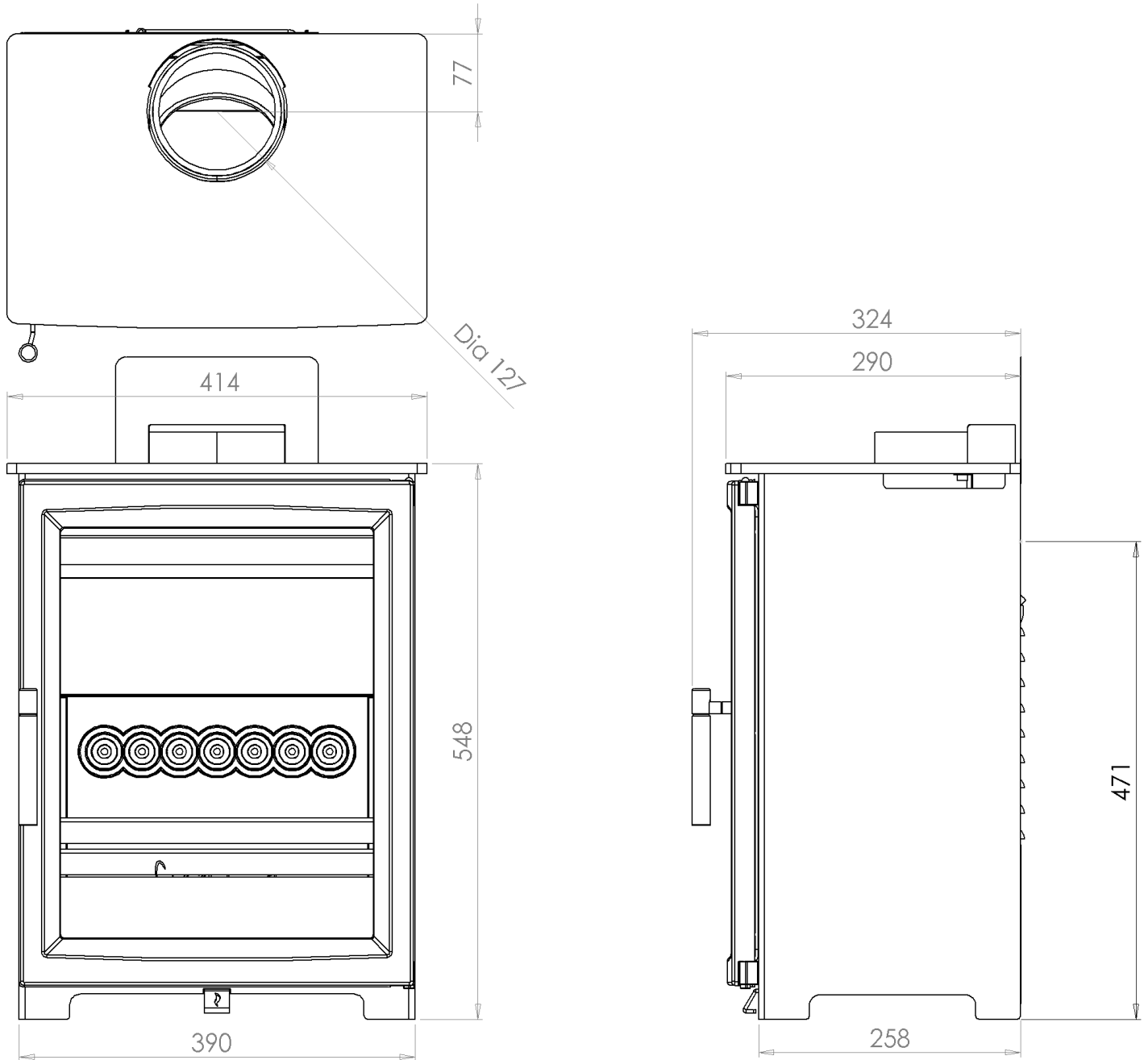

**NOTE:**

- Stands are available that increase the overall height by +76mm
- Log Stores are available that increase the overall height +236mm

## 9.2 Woodtec 5kW WIDE Stove Principal Dimensions

All Dimensions shown in mm.

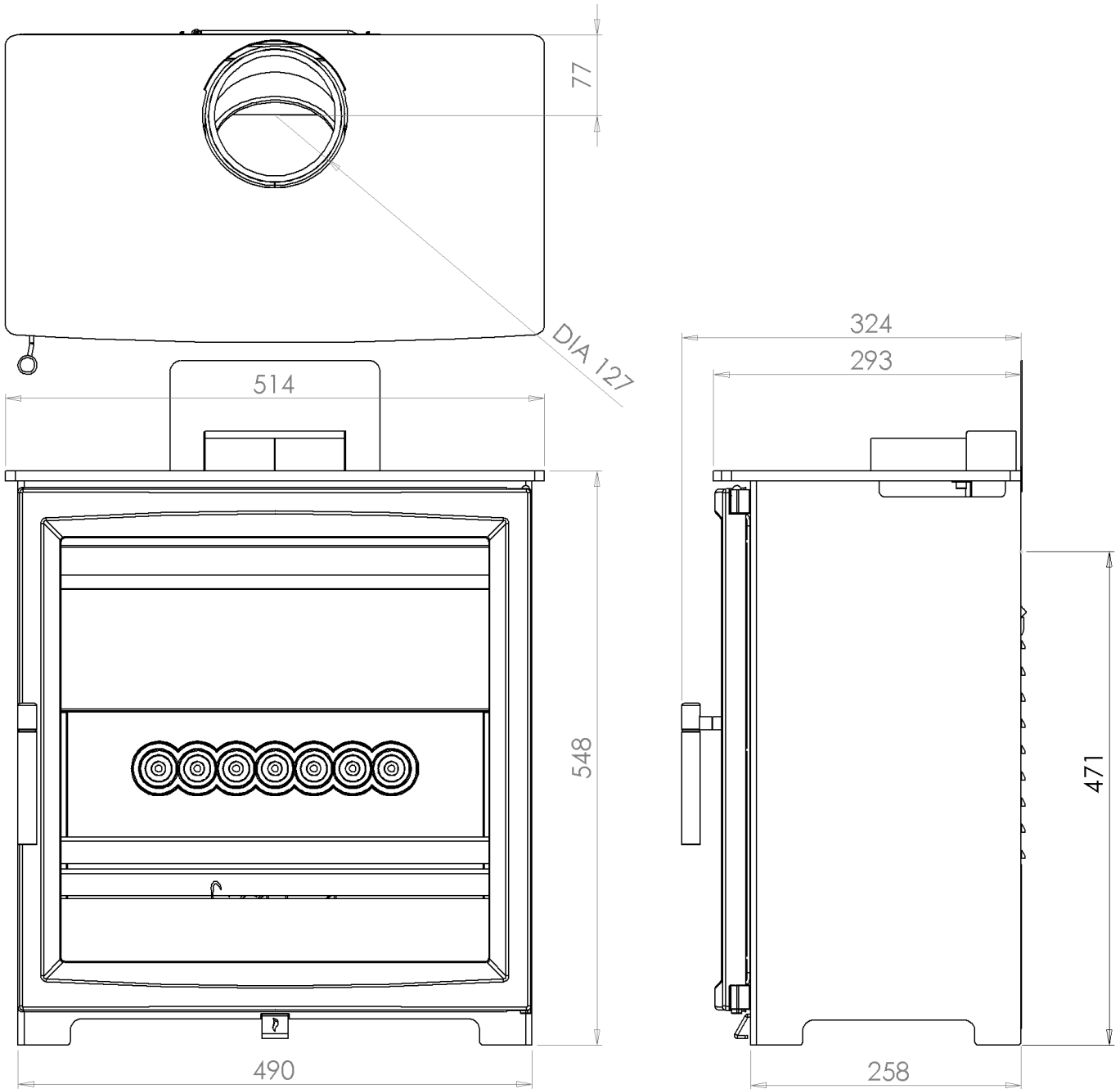

**NOTE:**

- Stands are available that increase the overall height by +76mm
- Log Stores are available that increase the overall height +236mm

### 9.3 Woodtec 5 WD (Wide Deep) and 5WD Catalytic Stove Principal Dimensions

All Dimensions shown in mm.

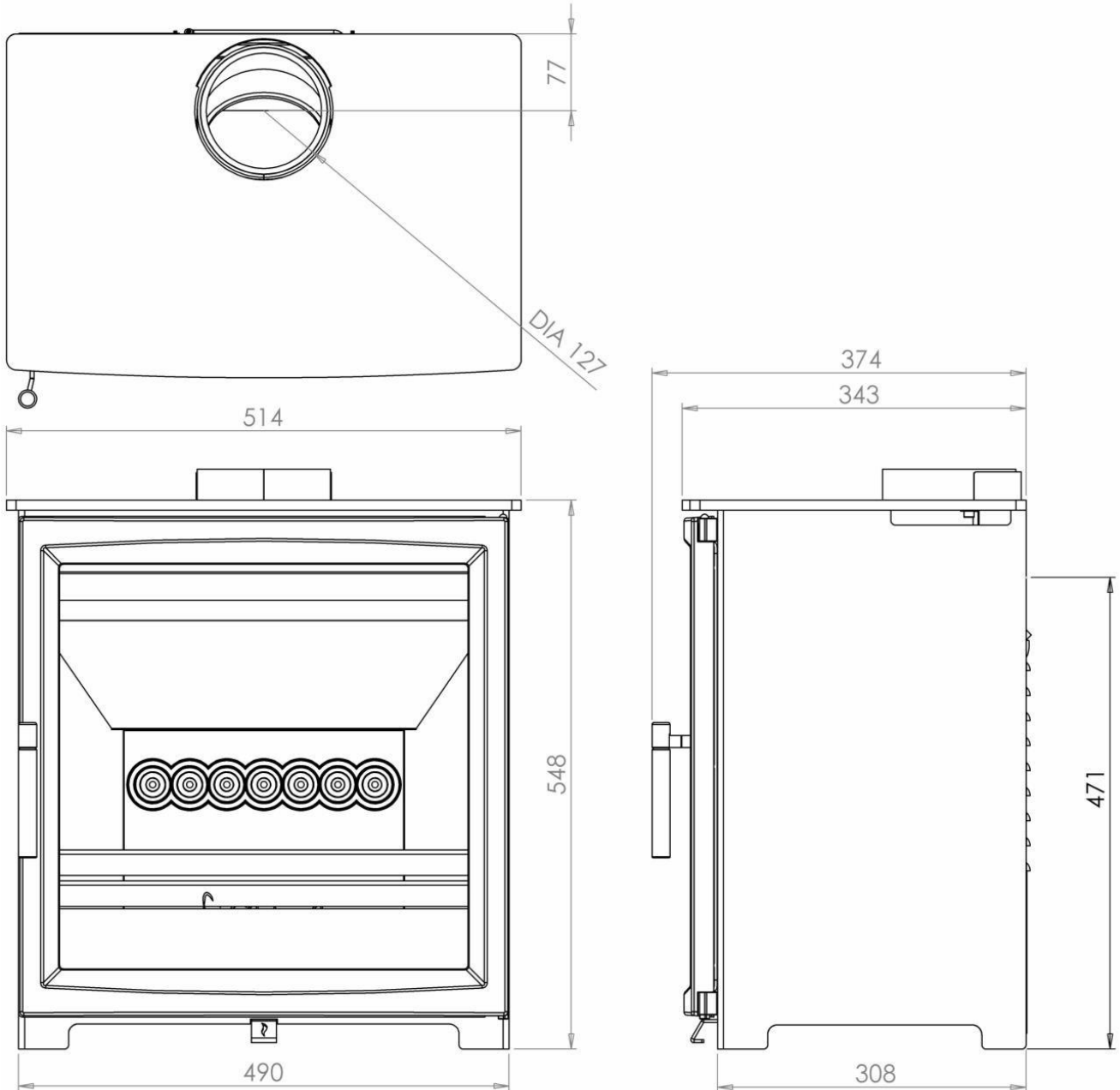

**NOTE:**

- Stands are available that increase the overall height by +76mm
- Log Stores are available that increase the overall height +236mm

## 9.4 Woodtec 5kW Xtra WIDE Stove Principal Dimensions

All Dimensions shown in mm.

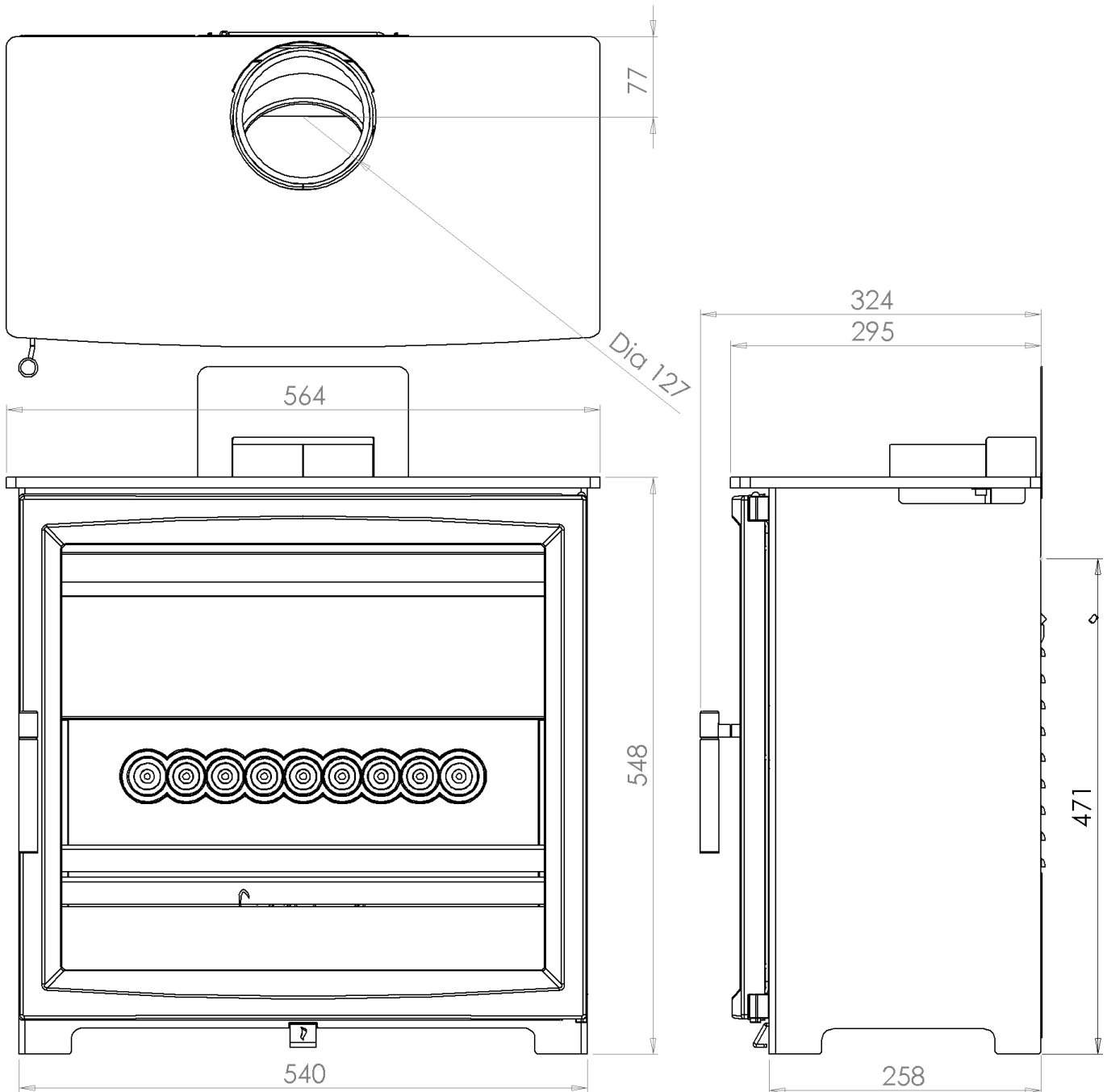

**NOTE:**

- Stands are available that increase the overall height by +76mm
- Log Stores are available that increase the overall height +236mm

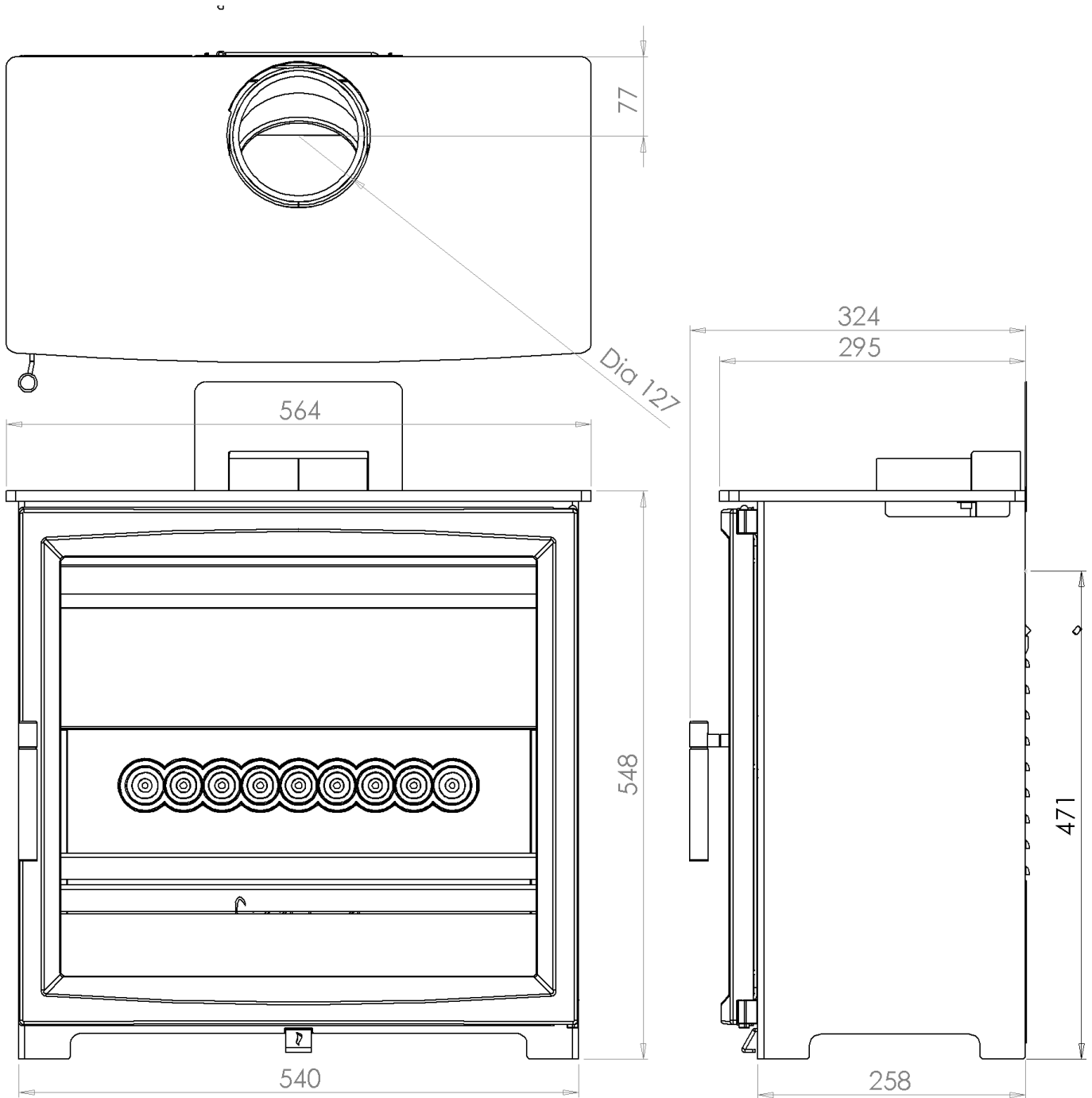

**NOTE:**

- Stands are available that increase the overall height by +76mm
- Log Stores are available that increase the overall height +236mm

## 9.5 Woodtec 5kW Style Stove Principal Dimensions

All Dimensions shown in mm.

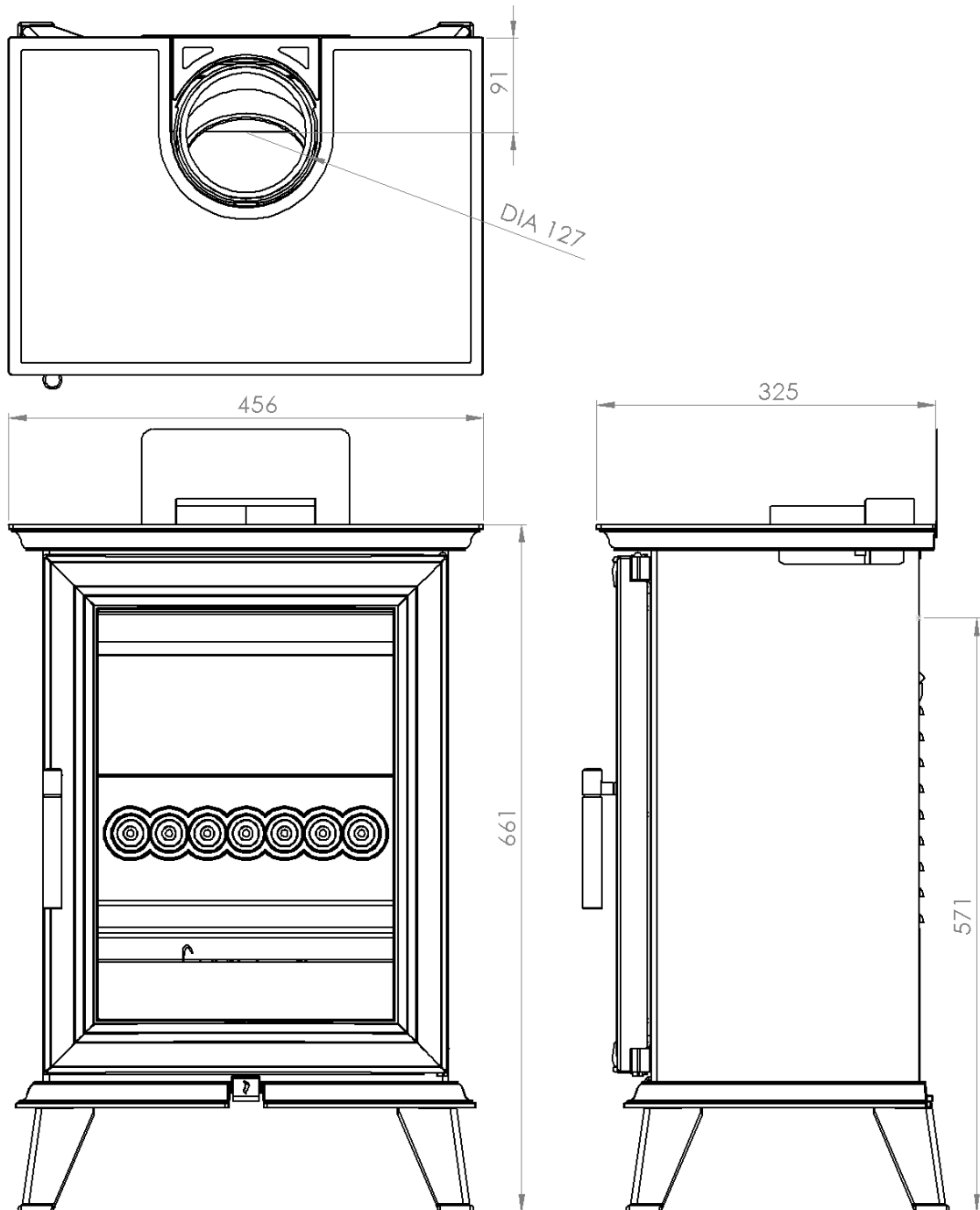



## 9.6 Woodtec 5kW WIDE Style Stove Principal Dimensions

All Dimensions shown in mm.

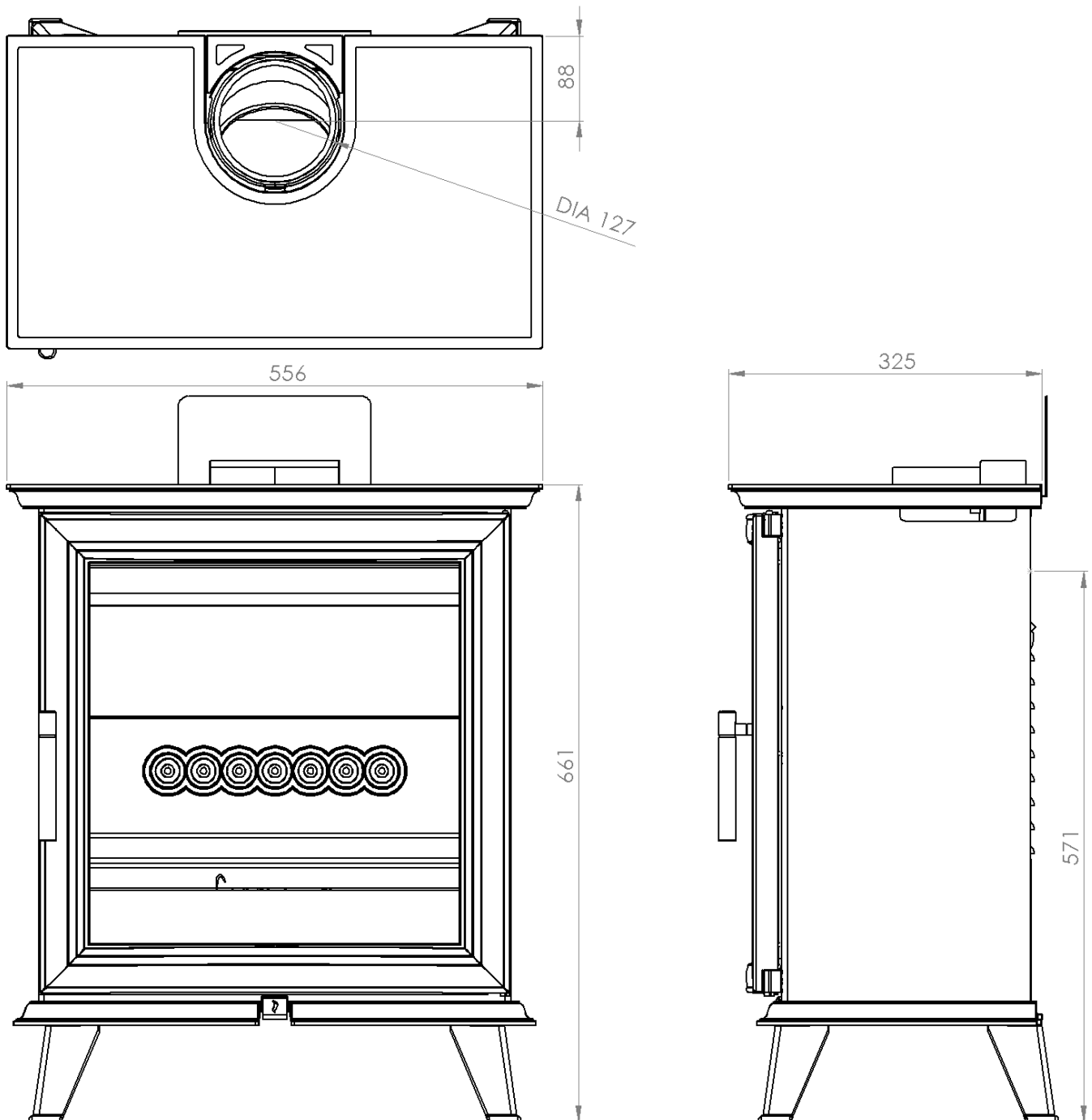

Blank Page

Blank Page

## **10.0 Frequently Asked Questions**

**1 Do stoves require a chimney or a liner?** All of our stoves require a suitable chimney or professionally installed flue system. A liner may or may not be required depending on flue conditions and only your installer can confirm. Our stoves do not mandatorily require a liner.

**2 How do I clean the chimney?** You will require a chimney sweep to clean the chimney. It is essential to provide a dedicated chimney cleaning access door when installing the flue of the stove in some situations. In many situations the chimney can be swept through the firebox.

**3 Who should install my stove?** Fireline want you to enjoy the maximum performance from your appliance. To ensure this, it is essential that they are installed correctly. We strongly recommend that your stove is installed by a suitably qualified installer e.g HETAS or OFTEC.

**4 How do I regulate the heat output?** Each stove has various air controls, which will allow you to easily regulate the heat output. Output can also be varied by log size and quantity fired.

**5 What warranty do I get?** Fireline will replace, free of charge, any part that fails (under normal operating conditions) within 12 months of purchase. Consumables such as glass, firebox lining materials or stove rope and adhesives are not guaranteed. We do not accept consequential or incidental liability claims from any product failure. **A call out charge will apply if our engineer attends any stove problem that is not related to product failure.**

**6 Where can I get spare parts?** Your local Fireline stove retailer will be pleased to supply spare parts and to provide any other information you require. Alternatively contact Fireline.

**7 Can the doors be left open while burning?** For safety and heat efficiency the doors should remain closed. These stoves are not designed or approved for doors open operation.

**8 Why is the stove smoking when lit?** A flue with lack of draught problems is almost certainly the cause of a smoking stove. Also check adequate ventilation is present – if opening a window or door stops the smoking then lack of ventilation is the probable main cause. A qualified fitter should complete both a smoke pressure and flow test prior to fitting the stove to ascertain the integrity of the flue.

**9 Why should I “Run in” my stove?** To begin, light a series of small fires over a period of a few days to allow the paint finish to cure. The stove is finished with a highly heat resistant paint. The finish can be renovated with stove paint available from your stove retailer. If the stove is not “run in” correctly, this may cause the paint to discolour and flake.

**10 What is Over Firing?** Over firing is overheating your stove by having the fire burning too fiercely. Your stove should never be used in a manner to cause over firing. Over firing can be caused by over loading the stove with fuel or leaving air controls fully open or operating the stove with leaking or defective door rope seals. If any part of stove glows red hot then your stove is over firing and your air control should be adjusted to reduce airflow to stove immediately. Over firing can cause permanent damage to the appliance, which is not covered by warranty.

---

**Fireline UK** – A division of **Charlton & Jenrick Ltd**  
Unit D Stafford Park 2, Telford, Shropshire, TF3 3AR

**T: 01952 200 444      F: 01952 200 480      [www.charltonandjenrick.co.uk](http://www.charltonandjenrick.co.uk)**

A Charlton and Jenrick Group Company