



## FGi, FXi & FPi 5 Taper INSET STOVE - V2 5 kW Nominal Output



# Installation and Operating Instructions



Please hand these instructions to the stove user when the installation is complete. Leave the stove ready for operation and instruct the user in the correct use of the appliance and operation of controls.

**Important:** – These products must be installed by a suitably qualified installer.

### DEFRA Clean Air Act Exemption

The **FGi/FXi/FPi 5 Taper** stove has been exempted under the Clean Air Act 1993 to burn seasoned wood logs in designated smokeless zones in the UK. This is subject to the correct fitting of the air control plate (the part and fitting instructions are supplied separately) maintaining the air wash control above a minimum setting at all times. **Instructions for wood burning MUST be followed in order to ensure compliance at all times.**

This appliance is guaranteed for 12 months subject to conditions. The extended firebox warranty will only be valid if the annual service plus flue sweeping has been carried out and noted on the warranty card and the appliance has been registered online.

**Register online today to activate warranty:** <http://www.charltonandjenrick.co.uk/warranty>

Fireline UK – A division of: Charlton & Jenrick Ltd, Unit D Stafford Park 2, Telford,  
Shropshire, TF3 3AR

T: 0845 519 5991 F: 0845 519 5992

**PLEASE READ ALL THESE INSTRUCTIONS CAREFULLY!**

**For safety reasons it is essential that your stove is correctly installed and operated. Fireline Stoves cannot accept responsibility for any fault or consequential problems arising through incorrect installation or operation.**

**TABLE OF CONTENTS**

<b>Section</b>	<b>Page No</b>
1. List of Components	2
2. Component Identification and Assembly	2
3. Installation Instructions	3
3.1 Warnings and important safety information	3
4 Installation Information	4
4.1 Chimney	4
4.2 Ventilation	4
4.3 Flue Draught	5
4.4 Connection to Chimney	5
4.5 Material Clearances	5
4.6 Hearths	6
4.7 Commissioning & Handover	6
5. Technical Data – Declaration of Performance (DoP)	7
6. Operating Instructions	7
6.1 DEFRA Clean air act	7
6.2 Air controls	8
6.3 Cleaning	9
6.4 Fuels	9
6.5 Notes on Smokeless fuel (Ancit) burning	9
6.6 Important Notes for Wood Burning	10
6.7 Lighting the stove	10
6.8 Re-fuelling	11
6.9 Shutting down	11
6.10 Shutting down for prolonged periods	12
6.11 Maintenance	12
7. Safety Notes for your Guidance	12
8. Dimensions	13
8.1 FGi/FXi/FPi5 Taper	13
9. Frequently Asked Questions	15

# 1. List of Components

Description of Parts	Qty
FGi/FXi/FPi Stove Assembly	1
Multi Tool	1
Ash Pan	1
Flue Spigot Collar	1
Spigot Collar fixing screws & nuts	3
Stove Operating Gloves	1

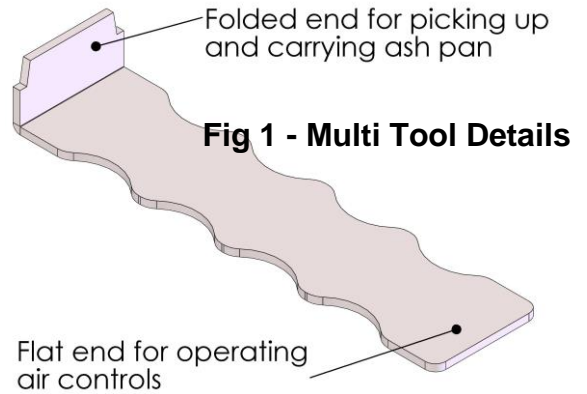

# 2. Component Identification and Preparations for Installation

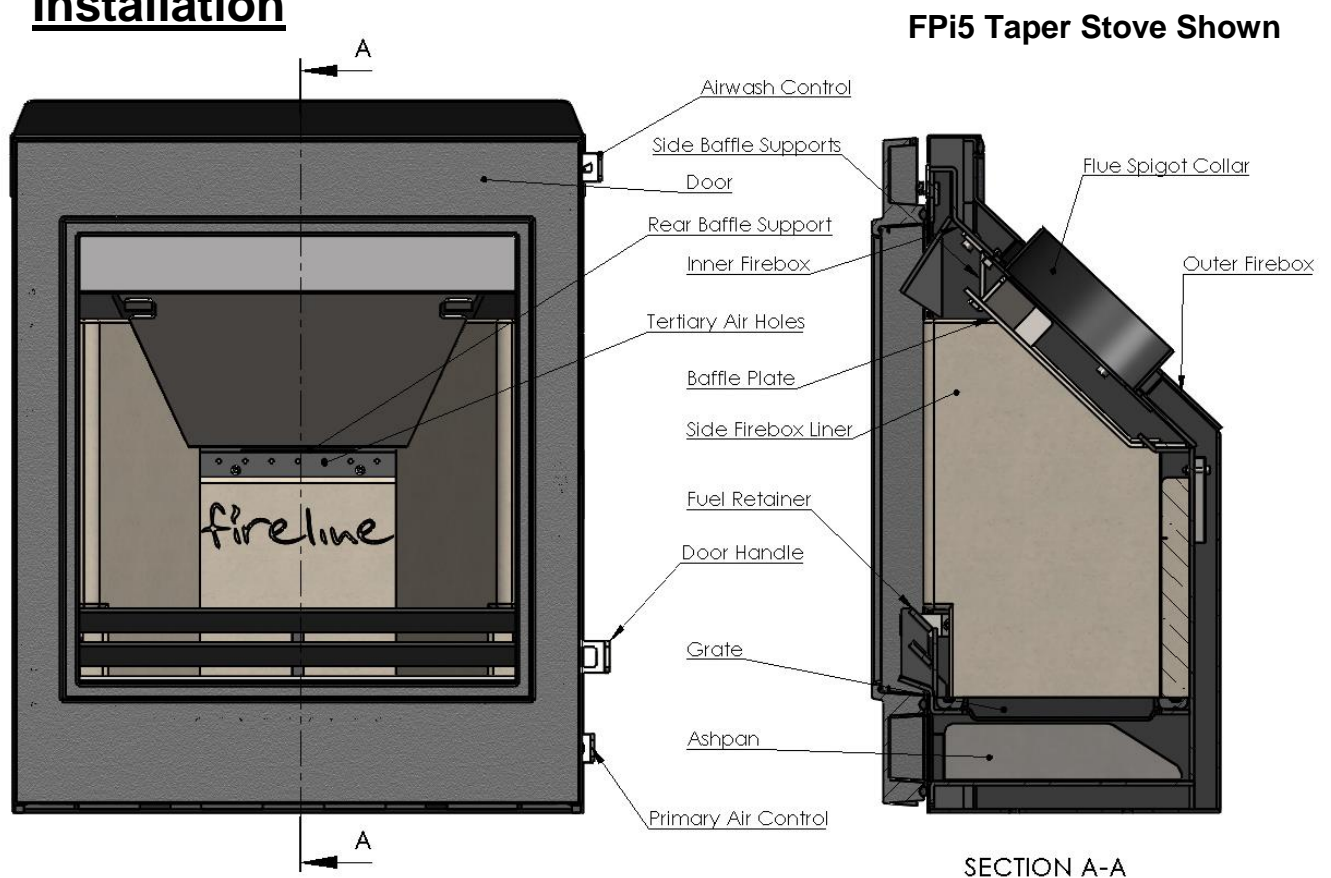

**Fig 2 – FGi/FXi/FPi 5 Taper Stove Assembly and controls**

Your stove comes packed in a plywood crate. Carefully remove the straps and lift off the upper crate. Remove any plastic packaging, open the door and remove all the contents. See List of Components section and check contents carefully.

- 2.1 To remove the baffle plate lift up and forward to disengage from its supports.
- 2.2 Now gently remove the two side firebox liners. Now remove the firebox rear liner and fuel retainer bars. Handle & store very carefully to one side where the liners will not get broken.
- 2.3 The flue spigot collar can now be removed from inside the firebox. Use 3mm ceramic gasket provided or fire cement to re-seal later.

- 2.4 To remove the door first release the 8 screws behind the door holding the metal wrap around trim to the firebox. When the trim is free the door can be lifted off its pins and placed out of the way.
- 2.5 Remove the metal outer trim to expose the firebox itself.
- 2.6 Remove the inner firebox from the outer firebox by releasing the 4 x countersunk screws from the support blocks each side of the firebox.
- 2.7 Place the inner firebox into the opening and drill and secure through the base to the hearth or into the wall/back panel through the sides of the casing.
- 2.8 Now proceed to install the stove according to these instructions and current installation standards or HETAS advice. The internal parts of the stove can be re-assembled as the reverse of the previous removal instructions.

## **3 Installation Instructions**

### **3.1 WARNINGS AND IMPORTANT SAFETY INFORMATION**

#### **3.1.1 READ THESE INSTRUCTIONS CAREFULLY BEFORE INSTALLATION!**

These instructions cover the basic principles to ensure satisfactory installation of the stove, although detail may need slight modification to suit particular local site conditions. In all cases the installation must comply with current local regulations including Building Regulations, Local Authority Byelaws and other specifications or regulations including UK or EU standards referred to as they affect the installation of the stove. Approved Document J is particularly important for England and Wales and can be downloaded for no cost at:

<http://www.planningportal.gov.uk/england/professionals/en/400000000503.html> Also of importance are Approved documents L1 A and B conservation of fuel and power. The Domestic Heating Compliance Guide will also be found useful.

In addition to these instructions the requirements of BS 8303 and BS EN 15287 must be fulfilled. The installation is a notifiable building works as defined in the building regulations and that it is a legal requirement under England and Wales Building Regulations that the installation is either carried out under Local Authority Building Control approval or is installed by a Competent Person registered with a Government approved Competent Persons Scheme. HETAS Ltd operate such a Scheme and a listing of their Registered Competent Persons can be found on their website at [www.hetas.co.uk](http://www.hetas.co.uk).

#### **3.1.2 Important Chimney Warning**

This stove must not be installed into a chimney that serves any other heating appliance.

#### **3.1.3 Extractor Fan Warning**

There must not be an extractor fan fitted in the same room as the stove as this can cause the stove to emit fumes into the room. If unavoidable the appliance must be checked with A.D. 1.21 and necessary action taken.

#### **3.1.4 Cleaning and Chimney Sweeping**

**The appliance, flue & chimney must be cleaned and checked internally and externally regularly in use and especially after a period of disuse (e.g. after summer).** Lift down the baffle at least weekly to check for build up of soot or debris on the top from the flue pipe. Remove the baffle and check the flue spigot and connector is fully clear at regular intervals. The chimney and flue connector must be swept at least annually, more often when used with sooty fuels or damp wood. A wire centred sweeps brush with guide wheel is recommended. Any loose, broken or leaking joints or flue ways **MUST** be repaired immediately.

### **3.1.5 Fuels**

Only use recommended fuels which are seasoned (or kiln dried) wood logs or smokeless briquetted fuels. The appliance can be damaged by burning petroleum coke, liquid fuels or general rubbish and this will invalidate your warranty and risk your personal safety. **The appliance must not be used as a rubbish incinerator.**

### **3.1.6 Maintenance**

Annual checking and servicing of the appliance and flue by a competent engineer is recommended.

### **3.1.7 Ventilation**

Adequate ventilation is ESSENTIAL for the safe and efficient operation of any solid fuel or wood burning appliance. Ventilation MUST be provided where required by the stove output or flue under-performance. Keep all ventilation clear and free of blockage. See VENTILATION in INSTALLATION section.

### **Health And Safety Precautions**

**Special care must be taken when installing this stove to meet all requirements of the Health & Safety at Work act.**

### **3.1.8 Handling**

Adequate facilities must be available for unloading and site handling. Fireline Stoves are very heavily built so always ask for assistance when lifting and siting the stoves.

### **3.1.9 Fire Cement**

Some types of fire cement are caustic and should not be allowed to come into contact with the skin. In case of skin contact, wash immediately with plenty of water.

### **3.1.10 Asbestos**

This stove contains no asbestos. If there is a possibility of disturbing any asbestos in the course of installation then please seek specialist guidance and use appropriate protective equipment.

### **3.1.11 Metal Parts**

When installing or servicing this stove, proper care should be taken to avoid the possibility of personal injury.

## **4.0 Installation Information**

### **4.1 Chimney**

The chimney height and the position of the chimney terminal should conform to Building Regulations. Minimum chimney height is 4.5m. Check that the chimney is in good condition, dry, free from cracks and obstructions. The diameter of the flue should not be less than 150mm and not more than 200mm. If any of these requirements are not met, the chimney should be lined by a suitable method. The chimney must be swept before connection to the stove.

Where the chimney is believed to have previously served an open fire installation, it is possible that the higher flue gas temperature from the stove may loosen deposits that were previously firmly adhered, with the consequent risk of flue blockage. It is therefore recommended that the chimney be swept a second time within a month of regular use after installation.

If you have any doubts about the suitability of your chimney, consult your local dealer/stockist or chimney specialist. If there is no existing chimney then either a solid

fuel compatible prefabricated block chimney or a twin-walled insulated stainless steel flue to BS 4543 can be used. These chimneys must be fitted in accordance with the manufacturer's instructions and Building Regulations.

#### **4.2 Ventilation**

Purpose provided ventilation is not required in England and Wales unless the appliance nominal rated output is greater than 5kW. Over 5kW 5.5 cm<sup>2</sup> of ventilation (550mm<sup>2</sup>) is required for every kW output above 5. For example 6.5 kW requires 8.25 cm<sup>2</sup> and 8 kW needs 16.5cm<sup>2</sup>. In any case, if difficulty in starting the fire or any fuming is experienced, ventilation must be put in place as required to eliminate these flue problems. If a flue draught stabiliser is fitted then extra ventilation is required. See Document J of the Building Regulations for detailed guidance especially in new build properties.

#### **4.3 Flue Draught**

A flue draught of minimum 1.2mm to a maximum 2.5mm water gauge (12 to 25 Pascals) is required for satisfactory appliance performance. When this is measured at the flue spigot collar it equates to 22 Pascal's MINIMUM to approximately 35-40 maximum. The flue draught should be checked under fire at high output and, if it exceeds the recommended maximum, a draught stabiliser must be fitted so that the rate of burning can be controlled to prevent over-firing.

#### **4.4 Connection to the Chimney**

This appliance is **not** suitable for use in a shared flue.

A flue liner may be used although is not required for operation of the stove. A sound and safe brick or clay lined chimney is acceptable. A reputable registered and experienced installer will advise. All installations must comply with Building Regulations.

An existing fireplace opening can be bricked up or sealed with a register plate. A short length of flue pipe of a minimum 125mm internal diameter (150mm min where the flue spigot socket is 150mm diameter) may then be used to connect the stove to the chimney or flue liner. A maximum of 150mm horizontal flue pipe can be used. This flue pipe should conform to Building Regulations. The stove should be insulated and properly fitted into the fireplace opening by back filling with 6:1 ratio vermiculite & cement mixture using minimal water through the top of the fireplace or flue spigot opening. The surface should be finished using 1:1:8 mix of cement, lime and sand. Any connecting pipe can be fitted and the spigot pushed up from inside the stove and rotated onto its keyhole slots to join to the pipe. Ensure that the pipe end is no closer than 76mm to the side or rear chimney walls.

Ideally, the old fireplace should be filled in so that there is a smooth streamlined entry into the flue way. It is essential that all connections between the stove and chimney-flue are sealed and made airtight with sealing rope, clamping rings and/or fire cement or heat resisting cement where required.

Both the chimney and flue pipe must be accessible for cleaning and if ANY parts of the chimney cannot be reached through the stove (with baffle removed), a soot door must be fitted in a suitable position to enable this to be done.

## 4.5 Material Clearances

### Safety Distances from Combustible Surfaces:

Model	Side	150mm Shelf	150mm Shelf - <u>WITH TOP DEFLECTOR</u>
FGi/FXi/FPi 5 T	150mm	400mm	125mm

**A stove top deflector heat shield is supplied with every stove to provide help for combustible shelves or surrounds that are closer than ideal to the stove top. With the deflector fitted a 6” combustible shelf can be maintained at minimum 125mm (5”) from the stove top. Fitting this part is optional and it does not affect stove operation at all.**

In addition it is strongly recommended that any furniture or other combustible materials are kept at least 900mm clear from the front of the stove.

As a guideline, materials that are in ‘line of sight’ to the stove are more likely to overheat than materials that are not in ‘line of sight’ due to direct radiation from the stove body. Materials above the stove are more likely to overheat than materials alongside or below. A guideline limiting temperature for solid timber (not surface finishes) is approximately 80-85 degrees C with a normal ambient room temperature. Temperatures of combustible materials can be substantially lowered with a simple heat shield constructed of a non-combustible material and small air gap between the shield and combustible material.

### Distances from NON-combustible materials:

The stove can be recessed in a suitable sized non-combustible fireplace. **Allow minimum 130mm clearance from the right side of the stove for door handle operation.** To conform to building regulations the fireplace recess walls should be at least 200mm thick or each rear leaf at least 100mm thick in the case of a cavity wall at the rear. If these dimensions are not met further protection for any combustible materials must be provided. The walls of the fireplace recess and the hearth must be made of non-combustible material.

### **4.6 Hearths:**

All FGi/FXi/FPi Taper inset stoves require a 125mm thick non-combustible constructional hearth beneath them to protect the building; this can include any solid non-combustible floor. A non-combustible superimposed hearth forming an apron of at least 225mm at the front of the stove and 150mm on either side must also be provided. The superimposed hearth must not be less than 12mm thick and must have a clearly defined edge (change of level) to discourage placing of any combustible materials on or partially over it. Ensure the hearth is flat & level and the back panel and surround are at right angles to the hearth.

The appliance shall be installed on a floor with adequate load-bearing capacity. If the existing construction does not meet this requirement, suitable measures (e.g. load distributing plate) should be provided to achieve it.

### **4.7 Commissioning and Handover**

A CO detector must be fitted in the same room as the stove according to current standards or codes of practice. Advise the customer of the importance of this device and maintaining it.

Upon completion of the installation, allow a suitable period of time for any fire cement and mortar to dry out. A small fire may then be lit and checked to ensure the smoke and fumes are taken from the stove up the chimney and emitted safely to atmosphere.

Advise the customer not to run the stove at full output for at 3 – 4 days. Explain that the stoves can provide much more or less than their rated heat outputs depending upon how they are burnt and fuels and fuel loads used.

**Warn the customer that using excessive air (having the air controls open too wide for too long) can over-fire and irreparably damage the stove. Damage caused by over firing is NOT covered by any warranty.**

On completion of the installation and commissioning, check that all parts of the appliance are correctly fitted and ensure that the operating instructions and operating tools (including gloves) for the stove are left with the customer. You must be sure to advise the customer on the correct use of the appliance with the fuels likely to be used on the stove and warn them to use only the recommended fuels for the stove.

Advise the user on what to do should smoke or fumes be emitted into the room from the stove – see **Safety Notes** section. The user should be warned that they **MUST** use a suitable fireguard in the presence of children, aged and/or infirm persons.



## 5.0 Technical Data

**Manufacturer:** Fireline UK Ltd, a Division of Charlton & Jenrick Ltd.

**Range Designation:** FG/FX/FP Taper Inset Stoves.

**Models:** FG/FX/FPi5T with nominal outputs of 5kW.

**Intended Use:** Domestic heating appliances without supply of hot water

**Independently Performance & Safety tested by:** Kiwa Gastec, Notified Body No: 0558

**Constasy of Performance System:** ISO9001

Model	FGi/FXi/FPi 5 Taper	Domestic Heating Appliance
Appliance gross weight (packed) (Kg):	75	
Harmonised Test Standard	EN13229: 2001 Amd 2: 2004	
Quality Constasy Standard	ISO9001	
Test Report Issue	6984	
Efficiency on wood fuel: (%)	79.7	
Declared nominal output: (kW)	5.0	
Tested wood re-fuelling interval: (h)	0.75	
Flue gas mass flow on wood fuel: (g/s)	3.9	
*Flue Temp on wood fuel: (Deg C)	279	*at nominal heat output
*Max Log Length:	2-300mm 9-12"	*Log length varies front to back due to taper.
Efficiency on Ancit fuel*: (%)	71.9	*With DEFRA air limiter fitted – approx. 79% without.
Declared nominal output on Ancit Fuel: (kW)	5.0	
Tested Ancit re-fuelling interval: (h)	1	
Flue gas mass flow on Ancit fuel: (g/s)	4.6	
*Flue Temp on Ancit fuel: (Deg C)	321	*at nominal heat output
<b>Safety Distances From Combustibles</b>		
Side (mm):	150	
150mm Shelf (mm):	400	
Shelf (with top deflector fitted) (mm):	125	

The performance of the products identified above is in conformity with the declared performance in the table.

**Signed:**



Peter Mintoft  
Director  
December 2014

**NOTE:** Refuelling intervals for testing are chosen according to the standards concerned for performance testing and are comparative only. They **do not** relate directly to re-fuelling intervals that can/might/will be achieved on an installed product. Re-fuelling intervals of 1-1.5h for wood and 3-4+ hours for Ancit would be more usual. Under normal conditions on a low air control setting stoves should stay in overnight on suitable briquetted smokeless fuel.

## **6.0 Operating Instructions**

This appliance is not designed for open operation and therefore should **not** be operated with the doors open.

This stove is designed to burn wood and smokeless fuels cleanly with high efficiency. However, for this product to work properly it must be used correctly. If used correctly this stove will burn with the very useful feature of clean glass.

It is **essential** that the stove has an adequate air supply for combustion and ventilation. The primary, secondary and tertiary air inlets must be kept clear from obstruction.

**Warning!** This appliance will be very **hot** when in operation and due care should be taken when operating the controls. A tool and a pair of high quality leather gloves are provided to assist safe operation.

Do not use an aerosol spray on or near the stove when it is alight.

### **6.1 The Clean Air Act 1993 and Smoke Control Areas**

Under the Clean Air Act local authorities may declare the whole or part of the district of the authority to be a smoke control area. It is an offence to emit smoke from a chimney of a building, from a furnace or from any fixed boiler if located in a designated smoke control area. It is also an offence to acquire an "unauthorised fuel" for use within a smoke control area unless it is used in an "exempt" appliance ("exempted" from the controls which generally apply in the smoke control area).

The Secretary of State for Environment, Food and Rural Affairs has powers under the Act to authorise smokeless fuels or exempt appliances for use in smoke control areas in England. In Scotland and Wales this power rests with Ministers in the devolved administrations for those countries. Separate legislation, the Clean Air (Northern Ireland) Order 1981, applies in Northern Ireland. Therefore it is a requirement that fuels burnt or obtained for use in smoke control areas have been "authorised" in Regulations and that appliances used to burn solid fuel in those areas (other than "authorised" fuels) have been exempted by an Order made and signed by the Secretary of State or Minister in the devolved administrations.

The Fireline FGi/FXi/FPi 5 Taper stove has been recommended as suitable for use in smoke control areas when burning wood logs. This is conditional upon fitting the supplied secondary air control (air wash) limiters and following the wood burning instructions precisely.

Further information on the requirements of the Clean Air Act can be found here: <http://smokecontrol.defra.gov.uk/>. Your local authority is responsible for implementing the Clean Air Act 1993 including designation and supervision of smoke control areas and you can contact them for details of Clean Air Act requirements

## **6.2 Air Controls**

### **Primary Air**

Primary air is controlled via the slider air control at the right side near the bottom of the door.

This provides a conventional air draught to the bed of the fire. The primary air intake needs to be adjusted to give the best results when burning different fuels. It will usually be closed when burning wood fuel and open when burning coal or smokeless type fuels.

### **Secondary Air (Air Wash)**

FGi/FXi/FPi Taper stoves are provided with a sophisticated patented “air wash” system. This secondary air supply to the stove is controlled through a slider assembly located on the top right hand side of the stove. If you want clean glass, always leave this control open some way whilst burning unless the stove is being shut right down for a long period. The only time this control should be fully closed is for maximum efficiency on Ancit fuel or for very slow burning on wood. The DEFRA air restrictor will deliberately prevent full closure of this control.

### **Tertiary Air**

This appliance is also fitted with a draught controlled tertiary air system that burns otherwise uncombusted gasses in the products of combustion thereby improving efficiency, increasing heat output and decreasing unwanted atmospheric emissions. The Tertiary air supply to the stove is controlled entirely by the draught in the flue and firebox. At certain stages of burning you will notice “jets” of flame emerging near the air holes to the rear of the firebox.

### **Multifuel Grate**

Your stove is fitted with a multifuel grate. The grate is a strong set of cast iron bars with suitable air slots that assist the burning of most fuels. When burning coal type fuels it is important to use a poker where required to de-ash regularly to ensure that the primary airflow is not impeded, as a build-up of ash *when burning coal* can damage the cast iron grate. A build up of wood ash when burning wood will not harm the grate and indeed wood burns better on a bed of ash. Excessive wood ash build up is not to be recommended however.

### **Ashpan**

It is essential that you empty the ash pan regularly when burning coal type fuels. Use the forked end of tool to lift the ash pan out of the stove. DO NOT allow coal ash to build up underneath the bed as this may cause damage to the grate.

## **6.3 Cleaning**

**Glass:** Despite the advanced air wash system provided, the glass will still need cleaning from time to time depending on the fuel quality and burning rates used. Never clean glass when the stove is hot. Always use stove glass cleaner or ceramic hob cleaner, which is available from your stove retailer. As an alternative, use a wet cloth with some of the wood ash if burning wood but be very careful to use very clean ash so as not to scratch the glass. DO NOT use coal ash to clean the glass.

**Outer body:** The outer body simply needs to be dusted from time to time. DO NOT use any kind of furniture polish or cleaning agent other than your stove suppliers recommended paint.

**Inner firebox:** Brush the inside of the firebox clean from time to time to check the integrity of the plates and liners etc. It is not normally necessary to re-paint inside the firebox due to the high temperatures that mean that the paint does not have much effect

before being burnt off. Steel and vermiculite board liners are resilient firebox materials and will give reliable service without major cleaning or work on the firebox. The liner boards may require replacement fairly regularly depending upon fuels and the type of usage experienced. Lining boards are not covered by warranty, as they are a wearing consumable part.

**Baffle:** It is essential to check the top of the baffle for build up of soot and ash regularly when in use and after a long period of no use. From time to time remove the baffle if necessary to ensure that the flue way entrance is clear.

#### **6.4 Fuels**

The appliance is fitted with a versatile multifuel grate and the appliance has been tested and approved burning dry, well-seasoned logs or Ancit smokeless fuel. These are the recommended fuels. For all other fuels please contact the manufacturer for advice.

**Warning!- Petroleum coke fuels or household waste must not be burnt on this appliance.**

Should any difficulties arise over fuel quality or suitability, consult your local approved fuel merchant.

#### **6.5 Important Notes for Wood burning**

With a full load of wood, the stove will need to be refuelled approximately every 1.5 hours. Wood can be stacked higher in the stove than solid mineral fuel but care must be taken that logs do not touch the baffle or the glass panel. **Do not stack logs above the level of the tertiary air inlets at the back of the stove.**

Wood burns most efficiently with the primary air controls closed and the secondary (air wash) controls a small amount open. Carefully adjusting the fuel load and secondary air controls will then control the burn rate of the stove. Always make sure that flames are visible above the wood after re-fuelling for cleanest burning. After re-fuelling open the air wash full for 3 to 5 minutes or until the logs are completely blackened to achieve full flames above the fuel.

Wood burns best on a bed of ash and it is therefore only necessary to remove surplus ash from the stove occasionally.

Burn only dry, well-seasoned wood, which should have been cut, split and stacked - under protection from rain - for at least 12-24 months with free air movement around the sides of the stack to enable it to dry out. Burning wet or unseasoned wood will create tar deposits in the stove and chimney and will not produce a satisfactory heat output. **Wood that is not properly dry ('dry' is considered to be less than 20% internal moisture content) uses up energy from the burn process to evaporate the water inside the wood thus creating very poor conditions for combustion.** The main cause of burning problems with wood stoves is due to excessively damp wood. Wood can appear perfectly dry on the outside but still contain 40-50% water on the inside. A moisture meter can be purchased from stove and equipment suppliers if you wish to check your wood source is correct.

##### **6.5.1 Refuelling on to a low fire bed**

If there is insufficient burning material in the fire bed to light a new fuel charge, excessive smoke emission can occur. Refuelling must be carried out onto a sufficient quantity of glowing embers and ash so that the new fuel charge will ignite in a reasonable period. If there are too few embers in the fire bed, add suitable kindling to prevent excessive smoke.

##### **6.5.2 Fuel overloading**

The maximum amount of fuel specified in this manual should not be exceeded, overloading can cause excess smoke.

### **6.5.3 Operation with door left open**

Operation with the door open can cause excess smoke and spillage into the room. The appliance must not be operated with the appliance door left open.

### **6.5.4 Primary Air left open**

Operation with the primary air controls left open can cause excess smoke. The appliance must not be operated with air controls or door left open.

### **6.6 Notes on Smokeless Fuel (Ancit) burning**

Ancit, smokeless and coal type fuels require very different burning conditions to log burning. When the stove is established and burning well, the air wash can be closed fully and the burning rate controlled with the primary air control and refuelling to obtain maximum efficiency. Ancit and other smokeless briquetted fuels can burn with very little primary air and stay in for many hours.

### **6.7 Lighting the Stove**

We recommend that you have two or three small fires before you operate your stove to its maximum heat output. This is to allow the paint to cure in steadily and to give a long service life of the paint finish. During this curing in process you may notice an unpleasant smell whilst the finishes finally cure. It is non-toxic, but for your comfort we would suggest that during this period you leave all doors and windows open.

First, open the primary and secondary air wash controls fully. Then load the firebox with plenty of starting fuel, i.e. paper, dry kindling sticks and/or firelighters. If using Ancit, place a layer of ancit into the firebox as well. Light the fire at the base leaving the air controls fully open. Leave the door slightly ajar for 10 minutes to enhance initial starting and reduce smoke emission – DO NOT leave the stove unattended if the door is left ajar. Allow the fuel to reach a steady glow and build the fire up gradually by adding a few small sticks, well split logs or Ancit briquettes at a time. Once you have a good fire bed established across the grate, further fuel can be added step by step as required. Don't be tempted to overload the fire bed with fuel all at once or close down the air controls too much until the fire is really well established for some time. Once the ignition period is well under way, gradually reduce the air control opening to establish the burning intensity you require. For wood burning the primary air control should be fully closed.

### **6.8 Re-fuelling**

When burning Ancit or other briquetted smokeless fuel, the fire will begin to die down with a significant amount of white ash showing amongst the fuel. Gently run a poker through the fire bed to remove most of the ash into the ashpan. Empty the ashpan if it is nearly full and then re-fuel with a good load of briquettes. The fuel load should initially be sloped from level with the top of the fuel retainer to not above the rear firebox liner board. Whilst approval test cycles are 1-2 hours, a stove burning Ancit may be kept in over night easily.

When burning wood, the fire will die down as the fuel is consumed. When the flames disappear and the remainder is breaking down into glowing embers it is an appropriate time to consider re-fuelling. **NOTE: If the flames disappear and there are still lumps of solid wood left this indicates excessive internal moisture in the wood or insufficient air supply/flue draught.**

NOTE: To eliminate unwanted smoke emission, after loading new logs on to the fire, open the air wash control up fully for 3-5 minutes or until the logs are blackened all over to boost the fire and get flames issuing from the top of the fuel as soon as possible.

When flames are well established, reduce the air wash to the running setting required. **Burning without flames above the fuel will create unnecessary smoke.** Do not load fuel above the tertiary air inlet holes at the back of the firebox.

Loading 3 to 4 medium sized logs will produce a good output with reasonable burn time, generally small logs will burn up quicker producing a high output for a short time and a large log will take longer to burn and produce less output over a given time. These appliances are approved for intermittent operation on wood (0.75 to 1.5 hour burn cycles) although much longer burn times can be achieved by fully loading the firebox, getting the fuel burning well and then shutting the air controls right down (see below). The fire will then need reviving by first opening the air controls and then using small pieces of wood and plenty of air to get flames issuing from the wood again.

### **6.9 Shutting Down**

The stove will normally shut down by itself as the fuel is consumed. In order to shut down the stove for other reasons, close the primary air controls (if open), then close the secondary air control. If the controls are left in this position, the fire will eventually go out. If you want to revive the fire it is recommended that the primary air controls are open first, and then open the secondary air controls.

**Warning!** - The stove will remain **very hot** for a considerable time after the fire has died down or been extinguished.

### **6.10 Shut down for prolonged periods**

If the stove is to be left unused for a prolonged period of time then it should be given a thorough clean to remove ash and unburned fuel residues. To enable a good flow of air through the appliance to reduce condensation and subsequent damage, leave the air controls fully open. It is important that the flue connection, any appliance baffles or throat plates and the chimney are swept prior to lighting up after a prolonged shutdown period.

### **6.11 Maintenance**

Inspect the inside of the firebox and above the baffle plate every week during use. Where the chimney is believed to have previously served an open fire installation, it is possible that the higher flue gas temperature from the stove may loosen deposits that were previously firmly adhered, with the consequent risk of flue blockage. It is therefore recommended that the chimney be swept a second time within a month of regular use after installation. **See chimney cleaning section in section 3.1 Warnings and Important Information.** Inspect the inside of the stove and the flue ways and ensure they are 100% clear after a period of disuse (e.g summer). **Only use manufacturers recommended replacement parts on the appliance**

## **7.0 Safety Notes for your guidance**

**FIRES CAN BE DANGEROUS** – Always use a fireguard to BS 8423:2002 Fireguards for use with solid fuel appliances in the presence of children, the elderly or the infirm.

**DO NOT perform modifications to the appliance as this could seriously compromise safety in operation.**

**DO NOT OVERFIRE** – it is possible to fire the stove beyond its design capacity, this could damage the stove, so watch for signs of over firing – if any part of the stove starts to glow red, including baffle plate or fuel retainer, the fire is in an over fire situation and the controls should be adjusted accordingly. Never leave the stove unattended for long periods without first adjusting the controls to a reduced and safe setting – **careful air supply control should be exercised at all times.**

### **WARNING – FUME EMISSION**

Properly installed and operated, this appliance will not emit fumes. Occasional fumes from de-ashing and refuelling may occur which is not normally of serious concern.

**However, persistent fume emission is potentially dangerous and must not be tolerated.**

If fume emission does persist, then the following immediate action should be taken: -

1. Open doors and windows to ventilate room and leave the premises.
2. Let the fire out, or remove and safely dispose of fuel from the appliance.
3. Check for flue chimney blockage and clean if required.
4. Do not attempt to re-light the fire until the cause has been identified and corrected.

If necessary, seek professional advice from chimney or stove specialists.

**Important!** – Do not fit an extractor fan in the same room as this appliance.

### **IN THE EVENT OF A CHIMNEY FIRE**

- Raise the alarm to let others in the house know.
- Call the Fire Service
- Reduce the appliance burning rate by closing all air controls fully.
- Move furniture and rugs away from the fireplace and remove any nearby ornaments.
- Place a fireguard or spark guard in front of the stove.
- Feel the chimneybreast for sign of excessive heat.
- Do not relight the fire until the chimney and flue ways have been examined by a professional.

If the wall is becoming hot, move the furniture away. Ensure that the Fire Service can gain access to your roof space in order to check this area for signs of fire spread.

### **CO ALARMS**

Your installer should have fitted a CO alarm in the same room as the appliance. If the alarm sounds unexpectedly, follow the instructions given under “Warning Note” below.

**WARNING** If the CO Alarm sounds unexpectedly:-

1. Open Doors and windows to ventilate the room and then leave the premises.
2. Let the fire go out.

## 8.0 FGi/FXi5/FPi5 Taper Stove Dimensions

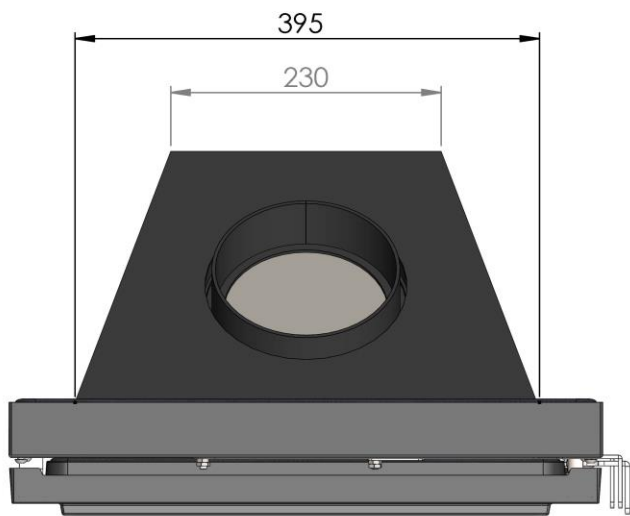

**Note: Allow minimum 130mm clearance from the right side of the stove for door handle operation**

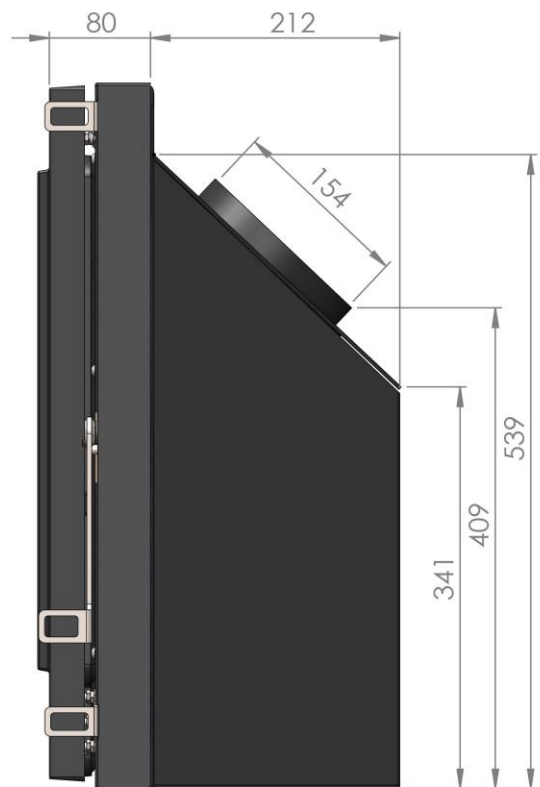
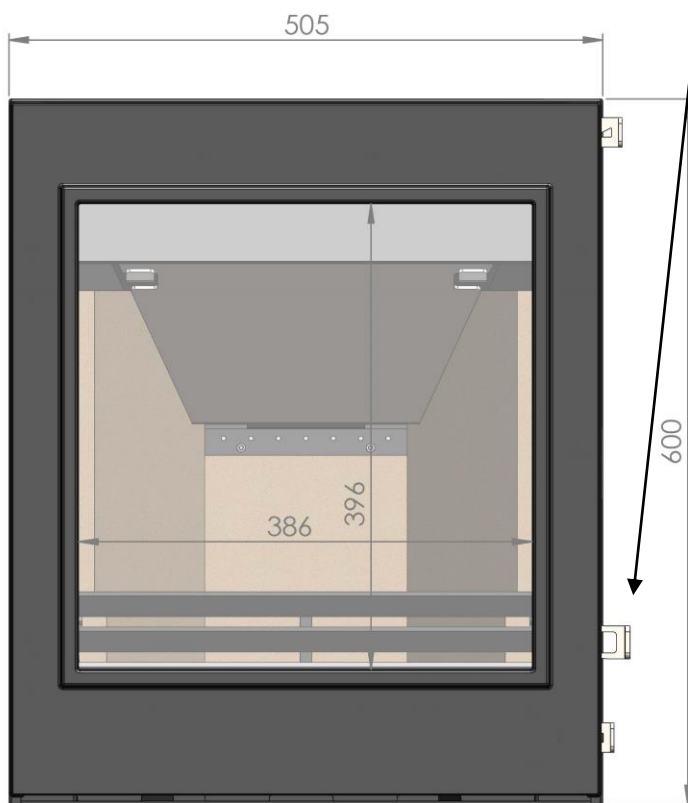



Blank Page

Blank Page

Blank Page

## **9.0 Frequently Asked Questions**

**1 Do stoves require a chimney?** All of our multi fuel and wood burning stoves require a suitable chimney or professionally installed flue system.

**2 How do I clean the chimney?** You will require a chimney sweep to clean the chimney. It is essential to provide a dedicated chimney cleaning access door when installing the flue of the stove in some situations. In other situations the chimney can be swept through the firebox.

**3 Who should install my stove?** Fireline want you to enjoy the maximum performance from your appliance. To ensure this, it is essential that they are installed correctly. We strongly recommend that your stove is installed by a suitably qualified installer e.g HETAS.

**4 How do I regulate the heat output?** Each stove has various air controls, which will allow you to easily regulate the heat output and refuelling rate.

**5 What warranty do I get?** Fireline will replace, free of charge, any working part that fails (under normal operating conditions) within 12 months of purchase. Consumables such as glass, firebox lining boards or stove rope and adhesives are not guaranteed. **A call out charge will apply if our engineer attends any stove problem that is not related to product failure.**

**6 Where can I get spare parts?** Your local Fireline Stove retailer will be pleased to supply spare parts and to provide any other information you require.

**7 Can the doors be left open while burning?** For safety and heat efficiency the doors should remain closed.

**8 Why is the stove smoking when lit?** A flue with back draught problems is almost certainly the cause of a smoking stove. Also check adequate ventilation is present. A qualified fitter should complete both a smoke pressure and flow test prior to fitting the stove to ascertain the integrity of the flue.

**9 Why should I "Run in" my stove?** To begin, light a series of small fires over a period of a few days to allow the paint finish to cure. The stove is finished with a highly heat resistant paint. The finish can be renovated with stove paint available from your local stove retailer. If the stove is not "run in" correctly, this may cause the paint to discolour and flake.

**10 What is Over Firing?** Your stove should never be used in a manner to cause over firing. Over firing can be caused by over loading the stove with fuel, and with primary controls open. If any part of stove glows "red" your stove is over firing and your draught control should be adjusted to restrict airflow to stove. Over firing can cause permanent damage to the appliance, which is not covered by warranty.

---

**Fireline UK – A division of Charlton & Jenrick Ltd**  
Unit D Stafford Park 2, Telford, Shropshire, TF3 3AR  
**T: 0845 519 5991 F: 0845 519 5992**  
**A Charlton and Jenrick Group Company**